



TS-650 With Collector Ring

Part Number: 153015 321 6W COVER

Designed for easy setup at a tradeshow, this unit is ready to go out of the box. It comes with an electrical cord for easy plug-in, a switch for changing direction easily, a rotating power outlet, and tough black powder coat.

Hanging Weight Capacity.....None
 Compressive Weight Capacity.....650 lbs [297.8 kg]
 Max Display Size.....6' x 6' (1.8m x 1.8m)
 Standard RPM.....2
 Torque Output @ 2 RPM.....95 in-lbs [10.7 Nm]
 Motor Draw.....0.13 A (16 watts)
 Safety Clutch.....Standard Feature
 Collector Ring Capacity.....15A at 115 V
 Shipping Weight.....36 lbs [16.3 kg]

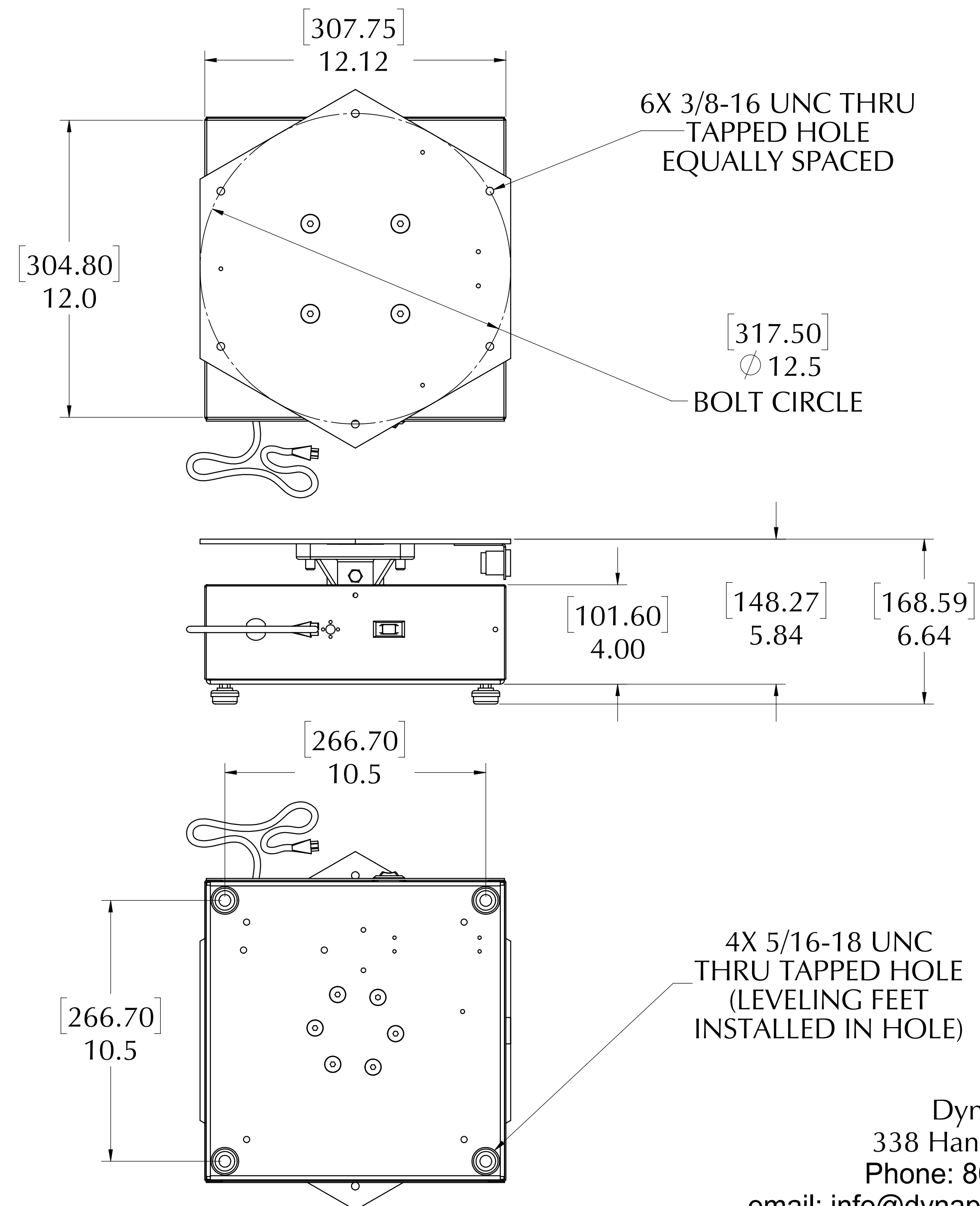
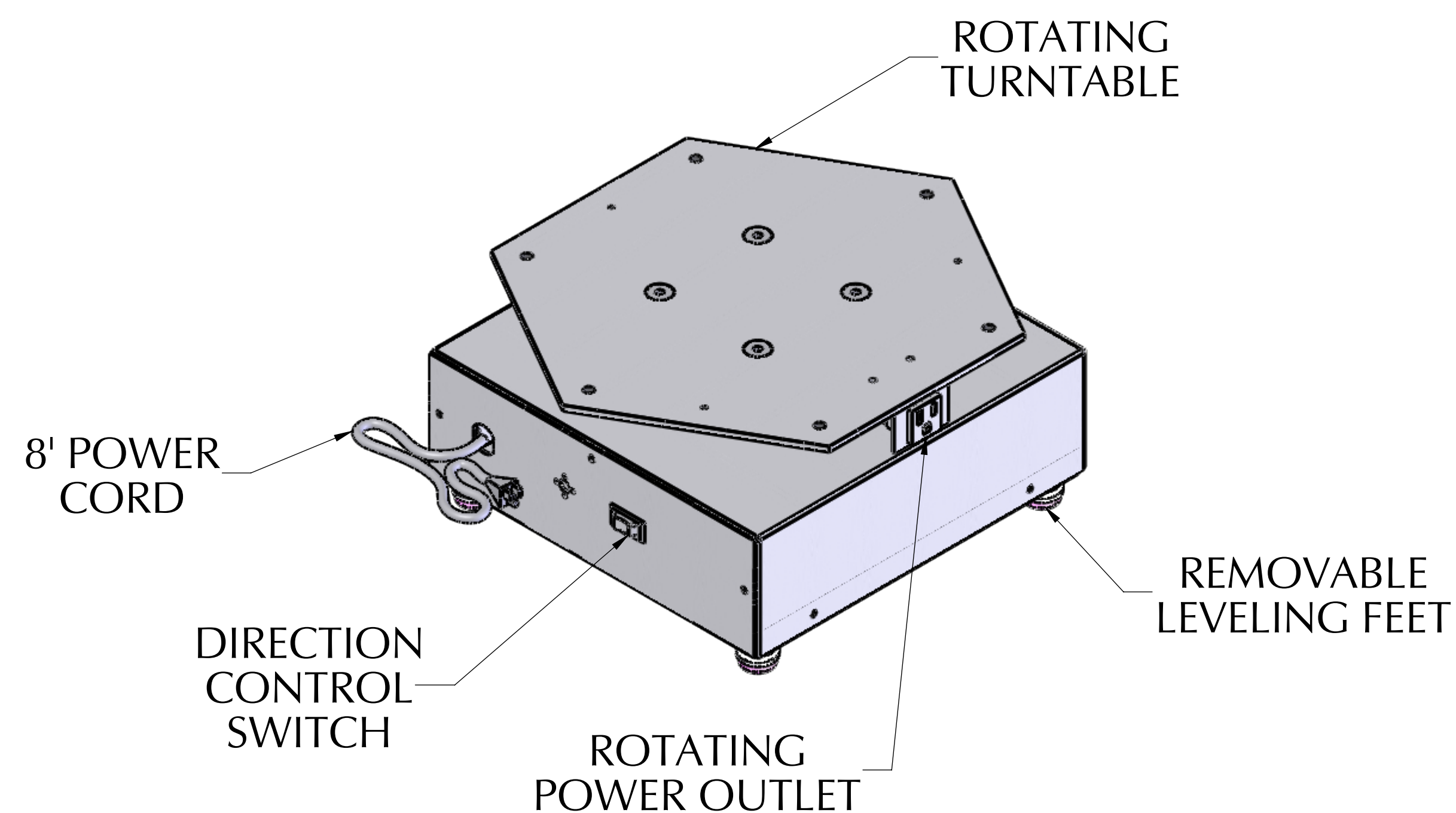

Dynapac Rotating Company Inc.
 338 Hansen Ave., Salt Lake City, UT 84115
 Phone: 801-485-2221 • Fax: 801-485-2254
 email: info@dynapacrotating.com • www.dynapacrotating.com