

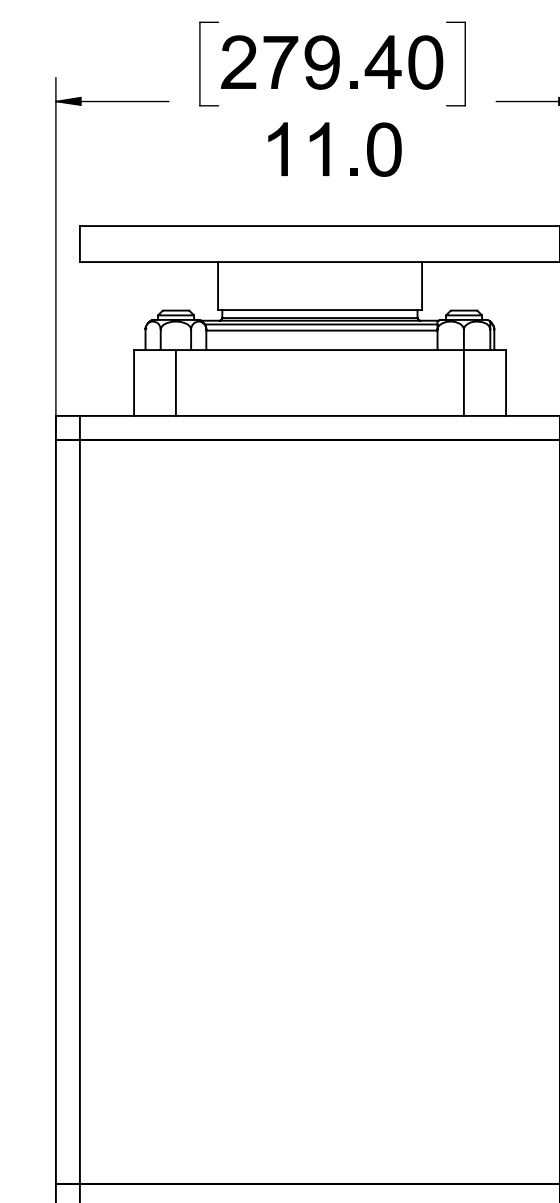

L-200

Part Number: 136002 341

Hanging Weight Capacity.....4200 lbs [1905 kg]
 Compressive Weight Capacity.....4200 lbs [1905 kg]
 Max Display Size.....Contact Dynapac
 Standard RPM.....4
 Torque Output @ 4 RPM.....350 ft-lbs [474.5 Nm]
 Motor Draw.....12 A (1440 watts)
 Safety Clutch.....Standard Feature
 Collector Ring Capacity.....15A at 115 V
 Shipping Weight.....250 lbs [113.4 kg]

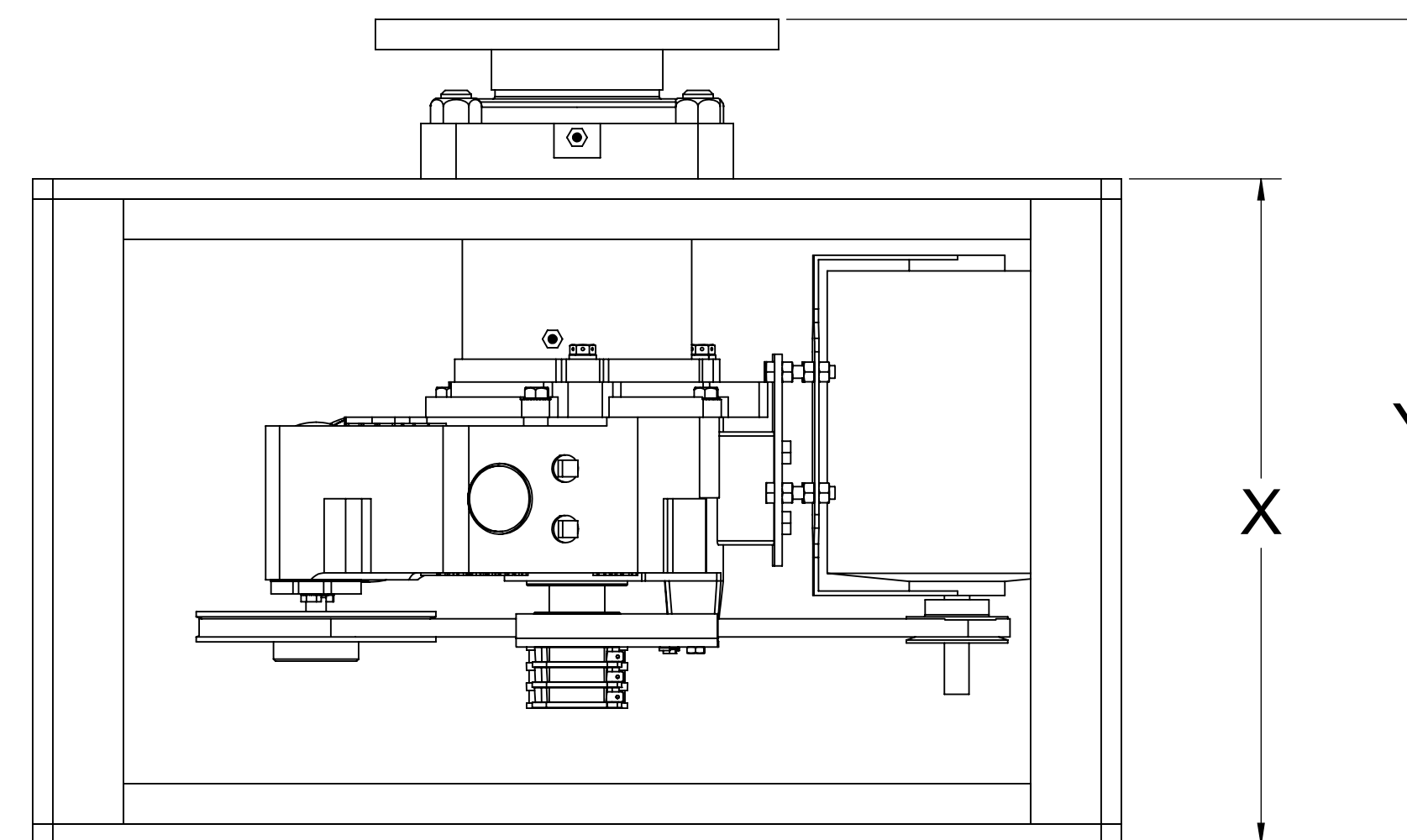
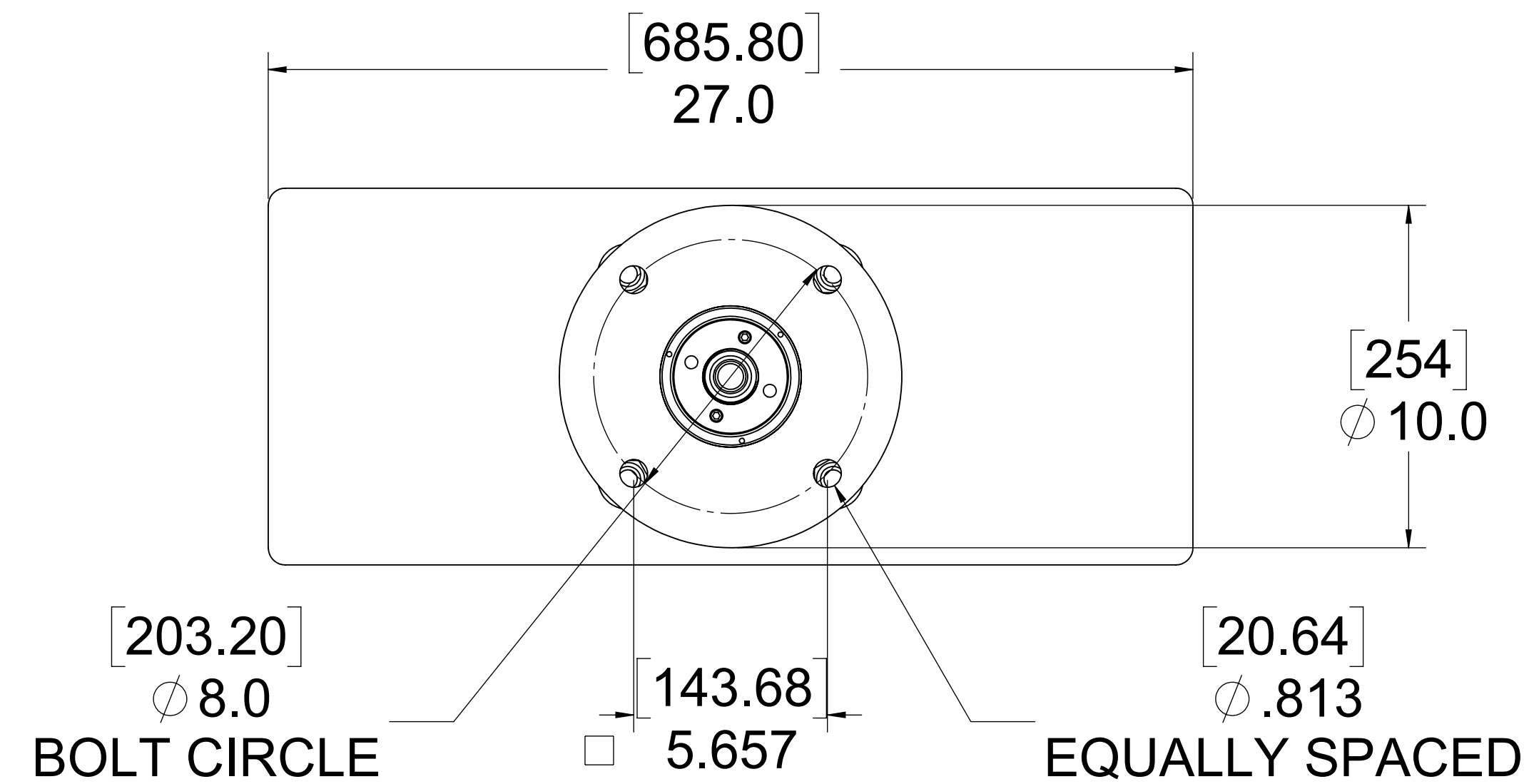
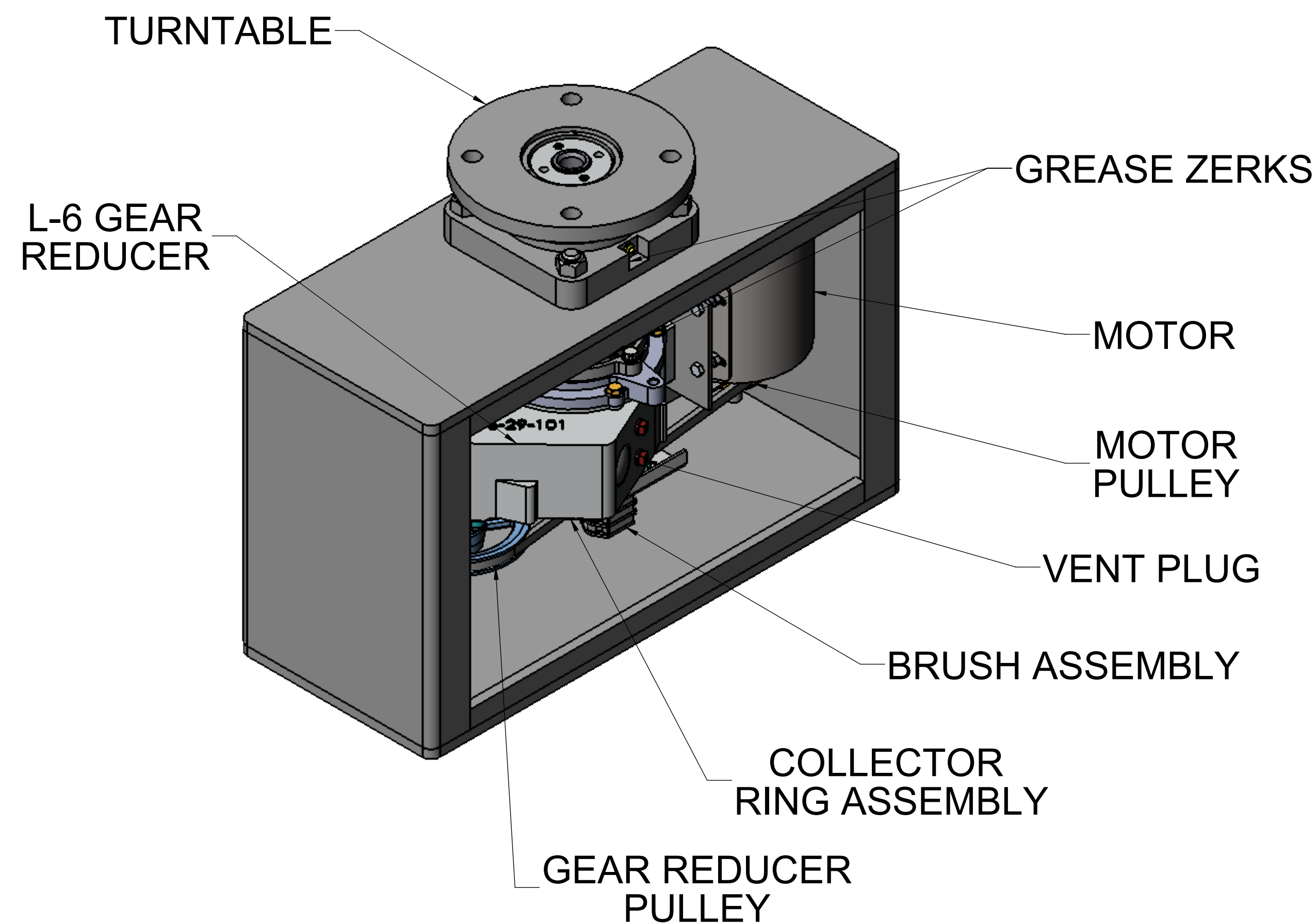

	X	Y
STANDARD FRAME	16.50" [419.10mm]	20.46" [519.60mm]
EXTENDED FRAME	22.50" [571.50mm]	26.46" [672.01mm]

NOTE: MAX COLLECTOR RINGS ON STANDARD UNIT IS 5.

Dynapac Rotating Company Inc.
 338 Hansen Ave., Salt Lake City, UT 84115
 Phone: 801-485-2221 • Fax: 801-485-2254
 email: info@dynapacrotating.com • www.dynapacrotating.com