

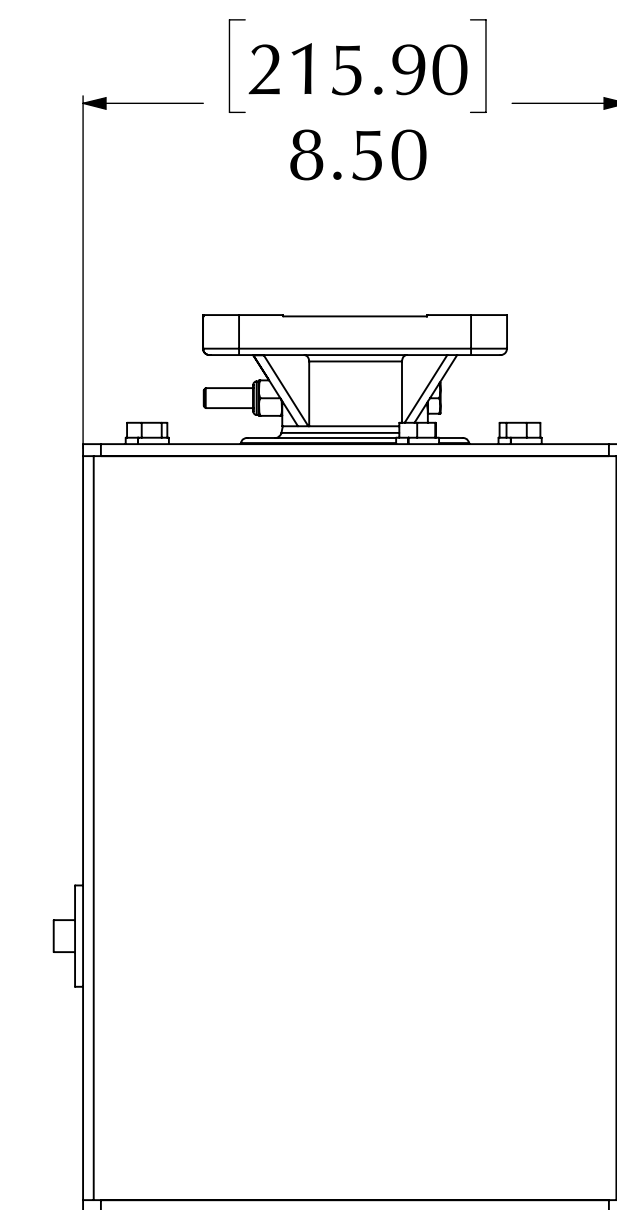

J-25

Part Number: 133005 361

Hanging Weight Capacity.....500 lbs [226.8 kg]
 Compressive Weight Capacity.....500 lbs [226.8 kg]
 Max Display Size.....Contact Dynapac
 Standard RPM.....6
 Torque Output @ 6 RPM.....100 ft-lbs [135.6 Nm]
 Motor Draw.....5.1 A (612 watts)
 Safety Clutch.....Standard Feature
 Collector Ring Capacity.....15A at 115 V
 Shipping Weight.....67 lbs [30.4 kg]

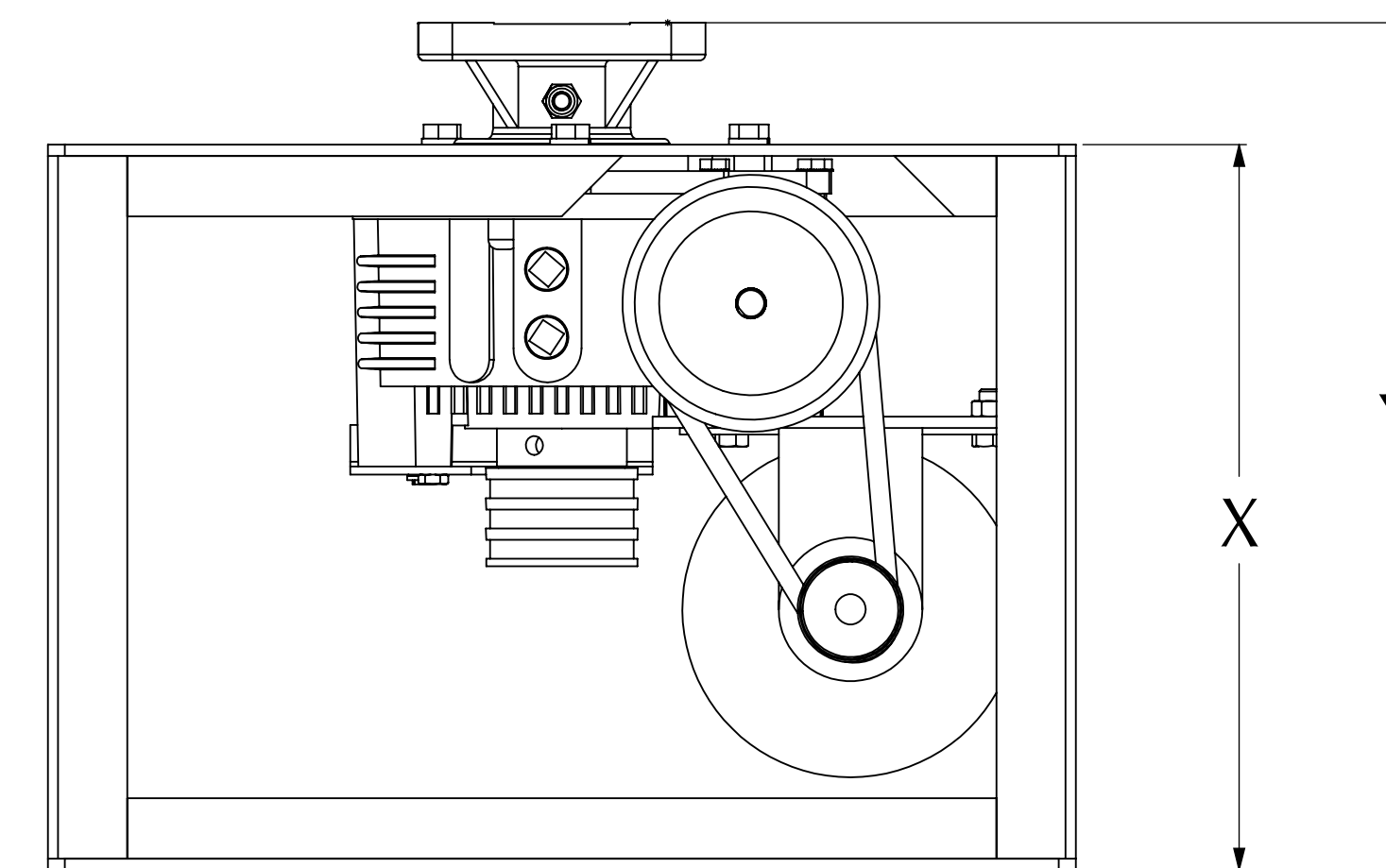
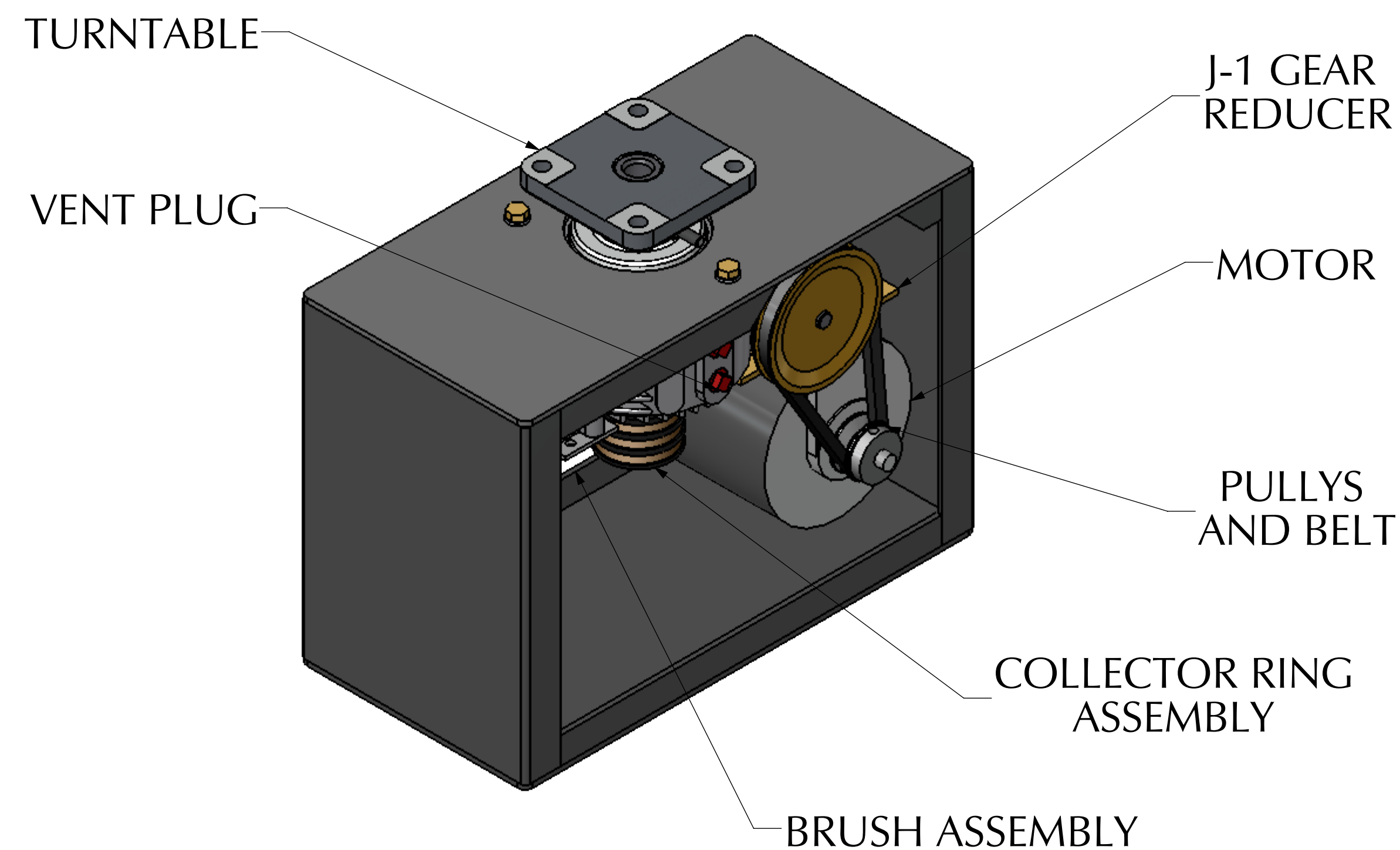
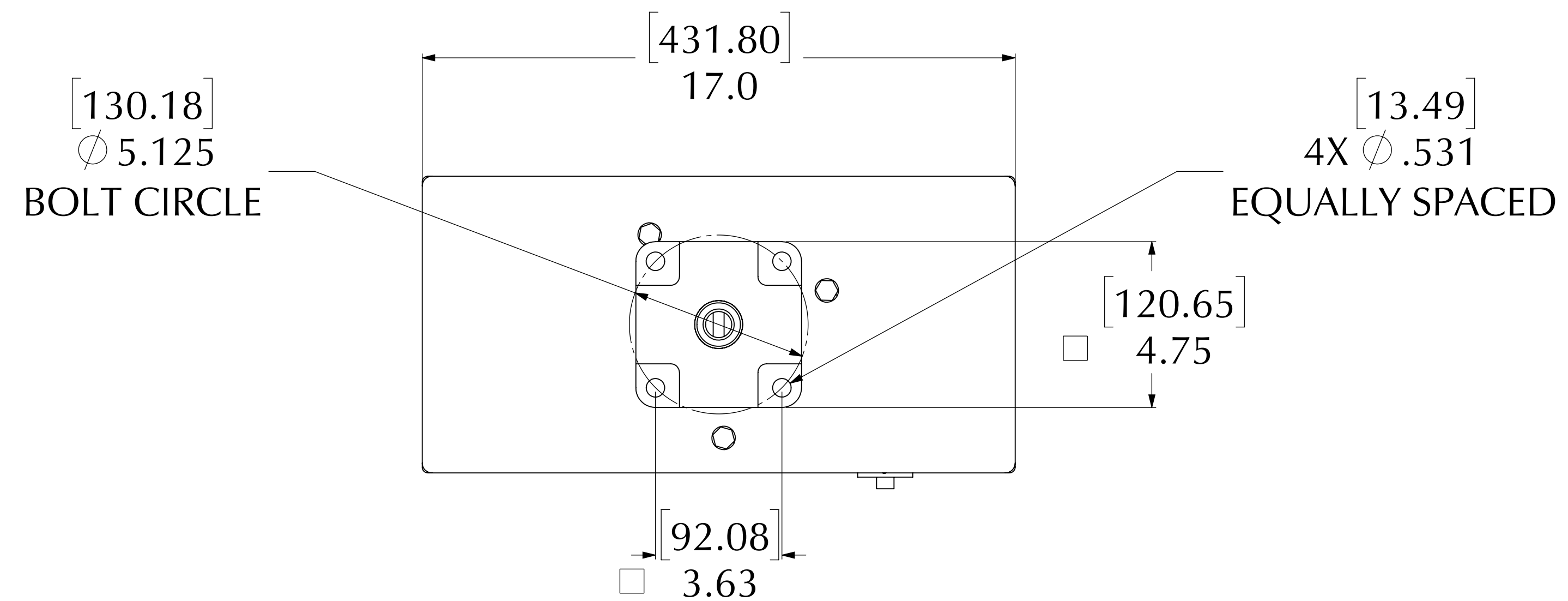

	X	Y
STANDARD FRAME	12" [304.8mm]	14" [356.02mm]
EXTENDED FRAME	18" [457.2mm]	20" [508mm]

NOTE: MAX COLLECTOR RINGS ON STANDARD UNIT IS 9.

Dynapac Rotating Company Inc.
 338 Hansen Ave., Salt Lake City, UT 84115
 Phone: 801-485-2221 • Fax: 801-485-2254
 email: info@dynapacrotating.com • www.dynapacrotating.com