



H-800 HANG With Collector Ring

Part Number: 153010 321 25W HANG

This indoor unit is ideal for larger diameter (greater than 15') and odd-shape banner signs. The oil-free gear box pre-vents oil leaks from happening during shipment and storage. Contact a Dynapac technical salesperson for help when selecting this unit.

Hanging Weight Capacity.....650 lbs [294.8 kg]
 Compressive Weight Capacity.....none
 Max Display Size.....Contact Dynapac
 Standard RPM.....2
 Torque Output @ 2 RPM.....168 in-lbs [19.1 Nm]
 Motor Draw.....0.46A (53 watts)
 Safety Clutch.....Standard Feature
 Collector Ring Capacity.....15A at 115 V
 Shipping Weight.....38 lbs [17.2 kg]

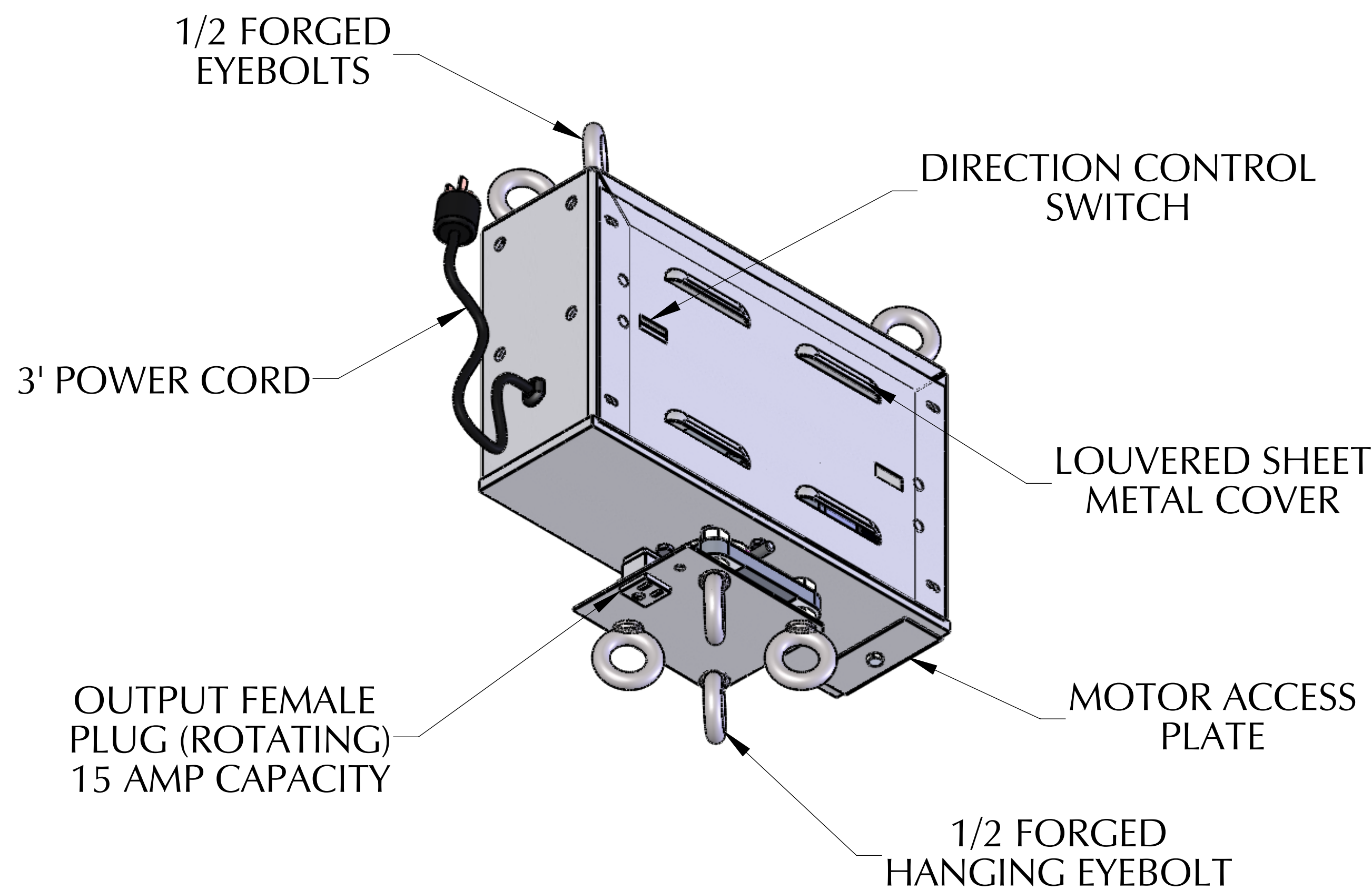
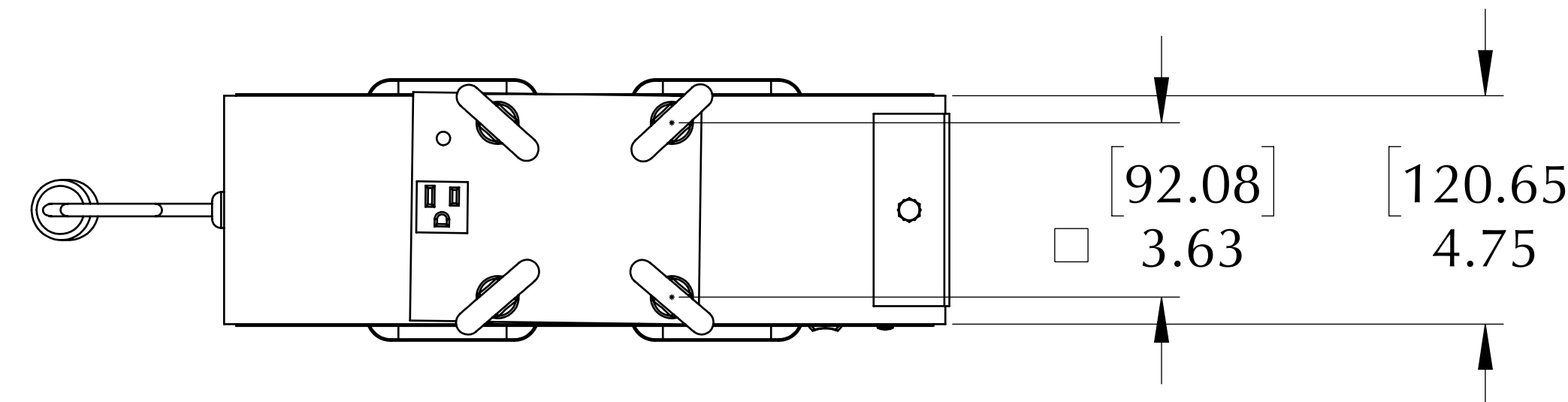
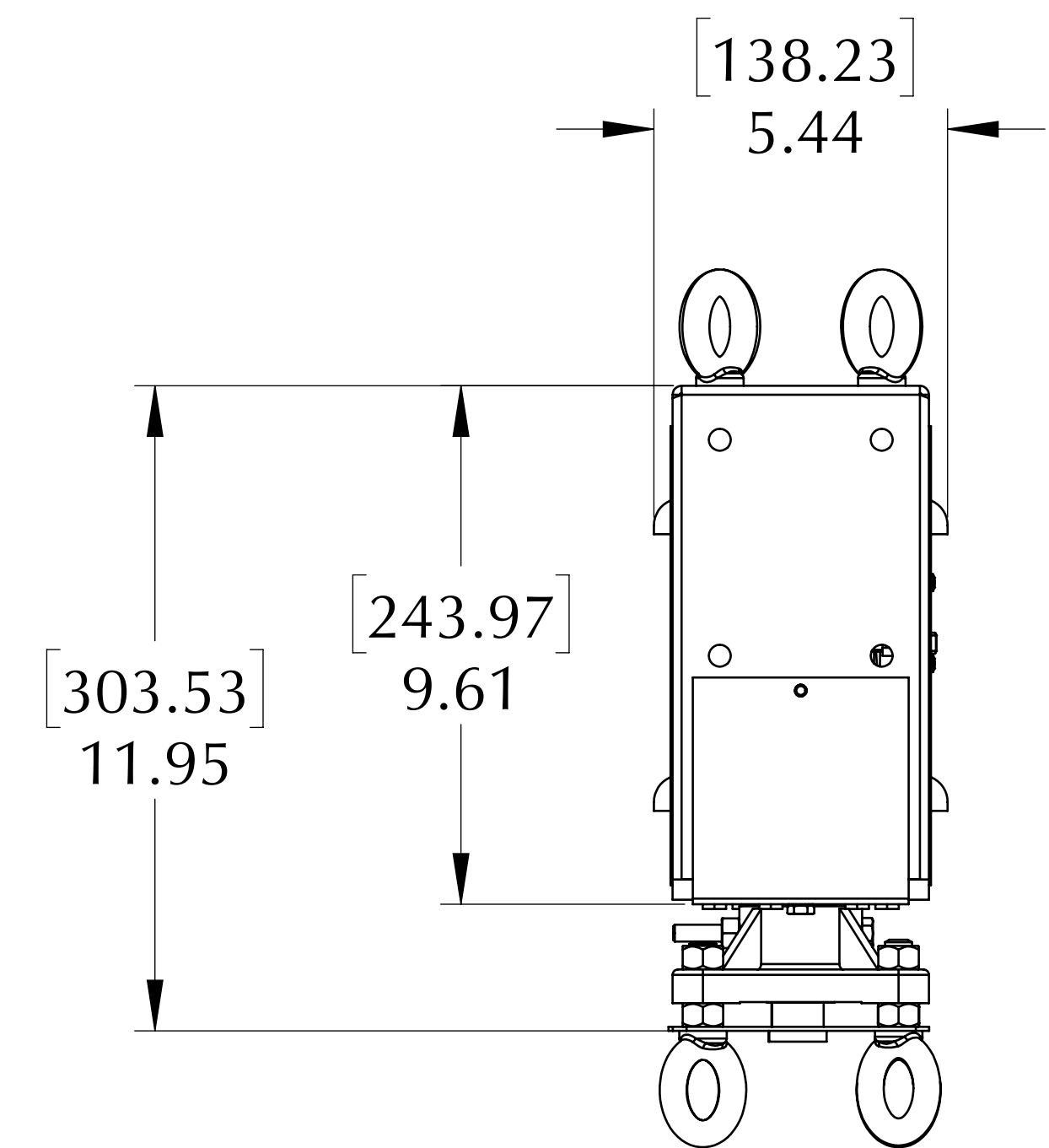
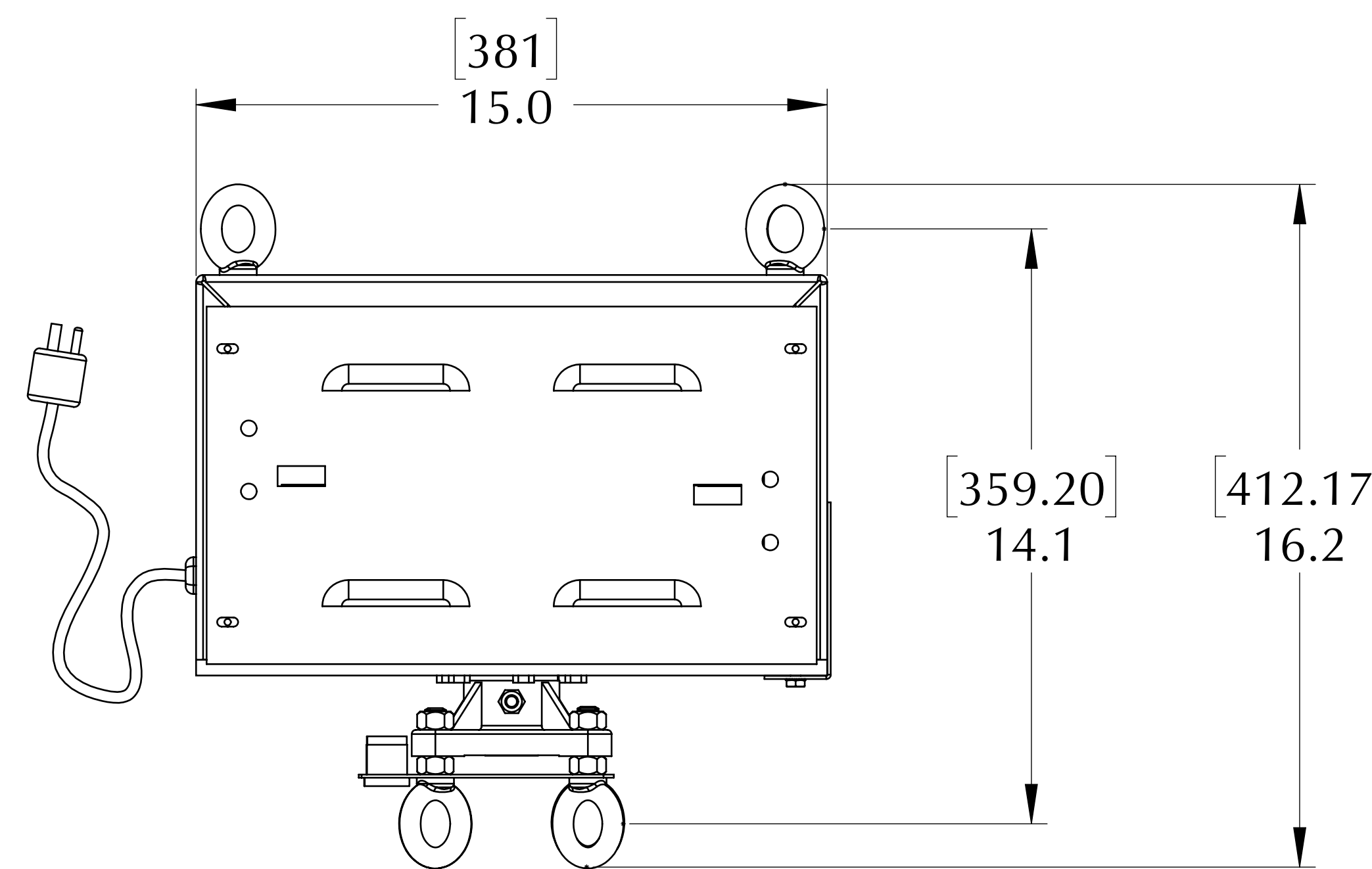
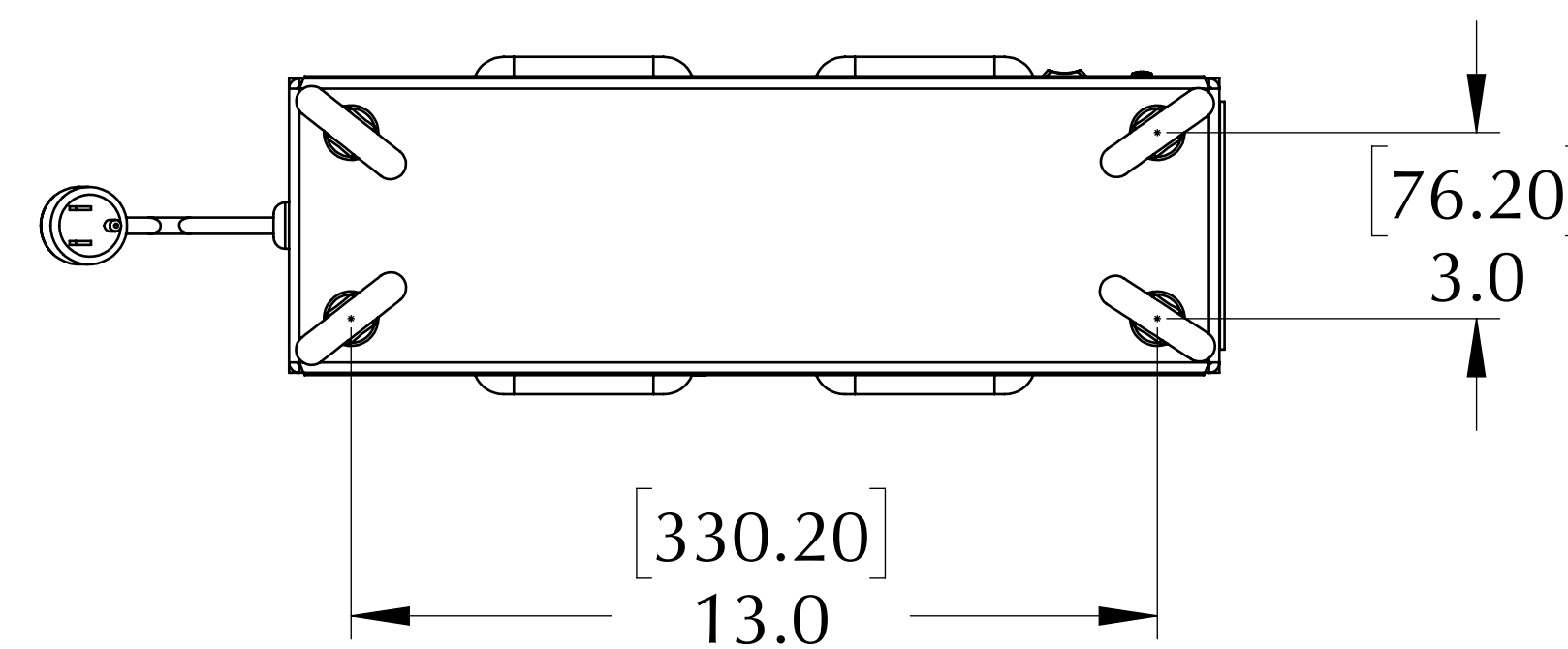

Dynapac Rotating Company Inc.
 338 Hansen Ave., Salt Lake City, UT 84115
 Phone: 801-485-2221 • Fax: 801-485-2254
 email: info@dynapacrotating.com • www.dynapacrotating.com