



H-650 With Collector Ring

Part Number: 153010 321 6W

This indoor unit is ideal for larger diameter and odd-shape signs and displays. The oil-free gear box prevents oil leaks from happening during shipment and storage.

- Hanging Weight Capacity.....500 lbs [226.8 kg]
- Compressive Weight Capacity.....650 lbs [294.8 kg]
- Max Display Size.....Contact Dynapac
- Standard RPM.....2
- Torque Output @ 2 RPM.....95 in-lbs [10.7 Nm]
- Motor Draw.....0.2 A (24 watts)
- Safety Clutch.....Standard Feature
- Collector Ring Capacity.....15A at 115 V
- Shipping Weight.....35 lbs [15.9 kg]

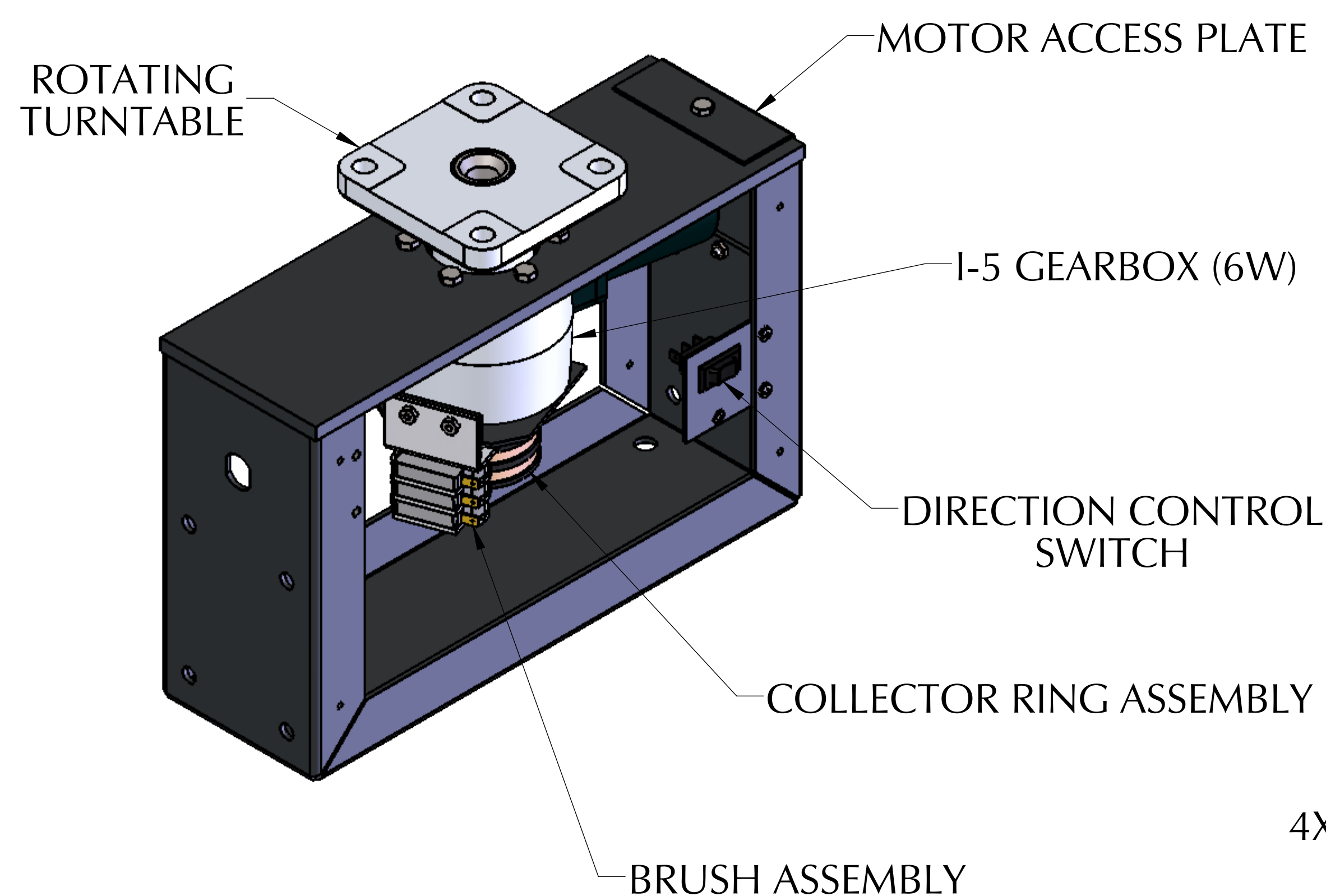
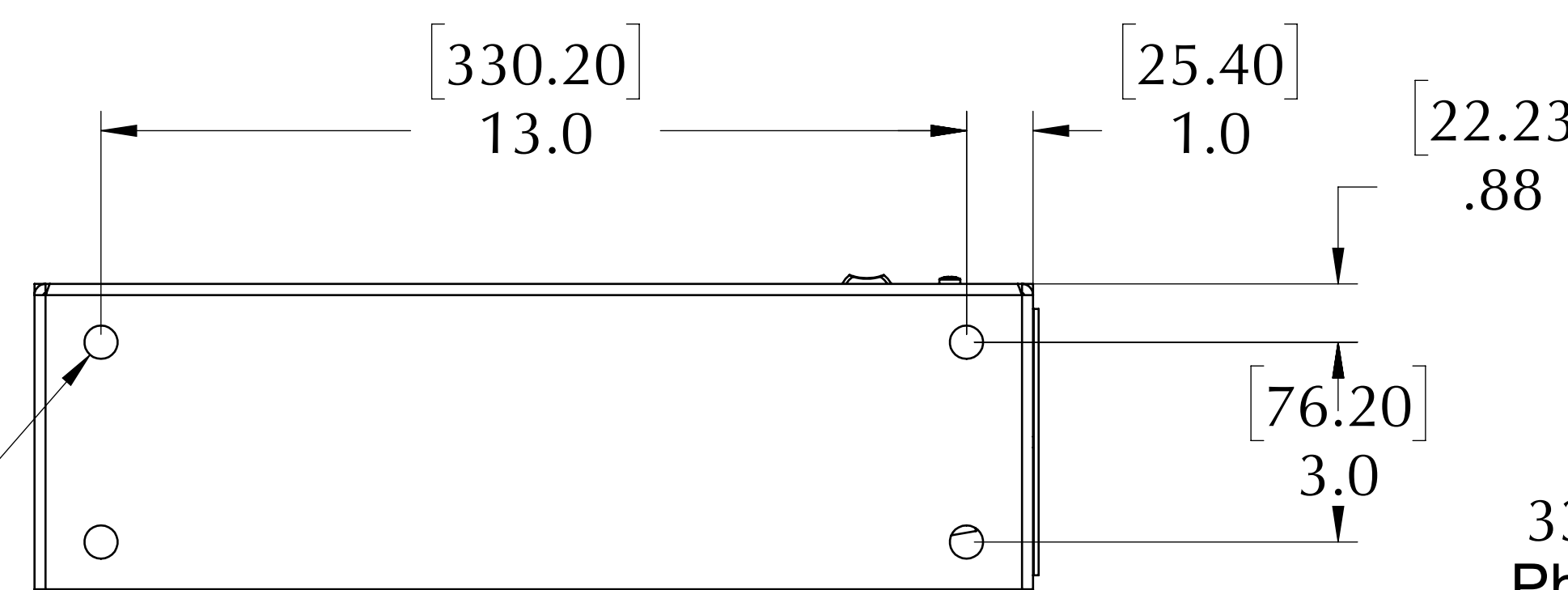
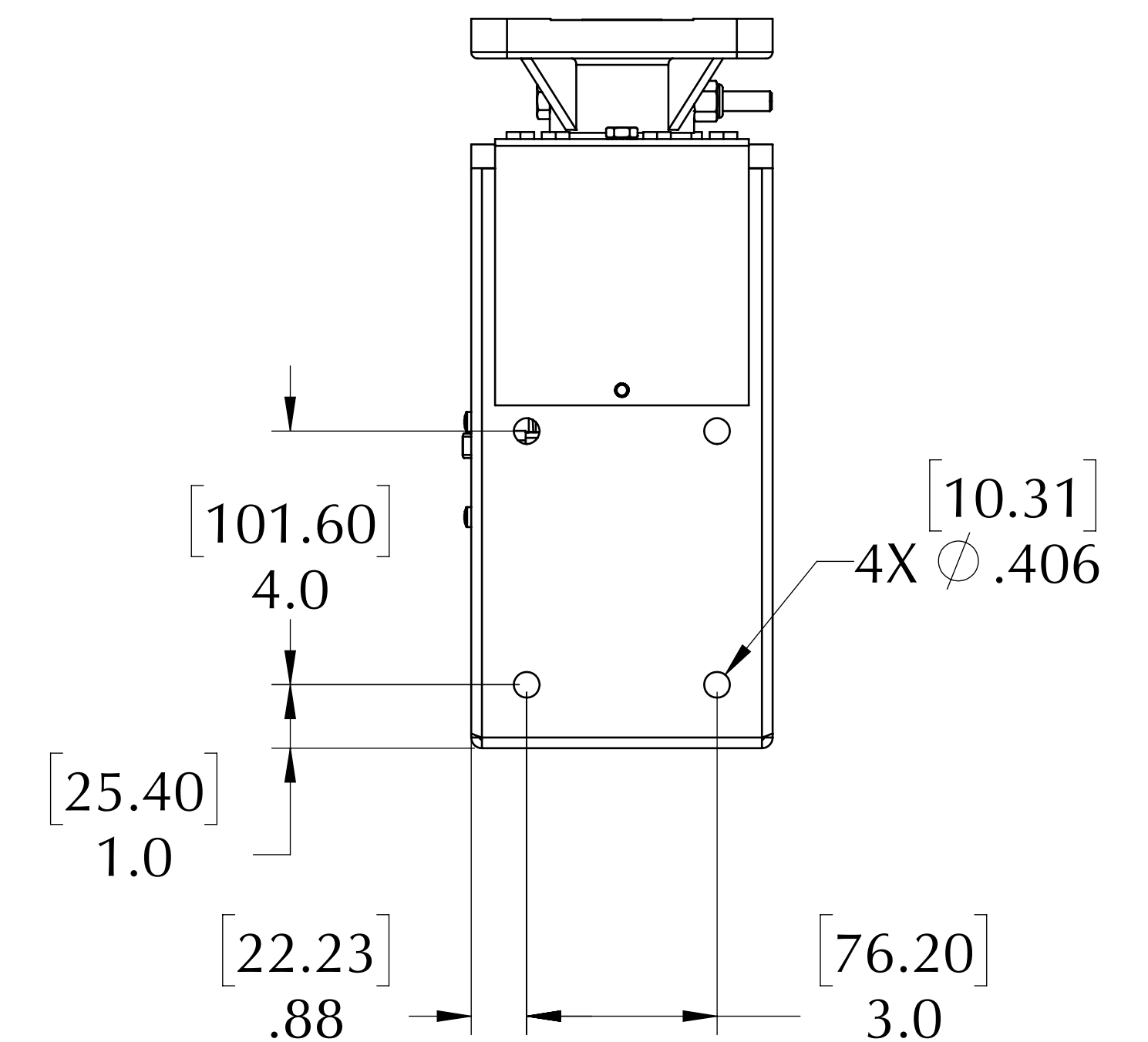
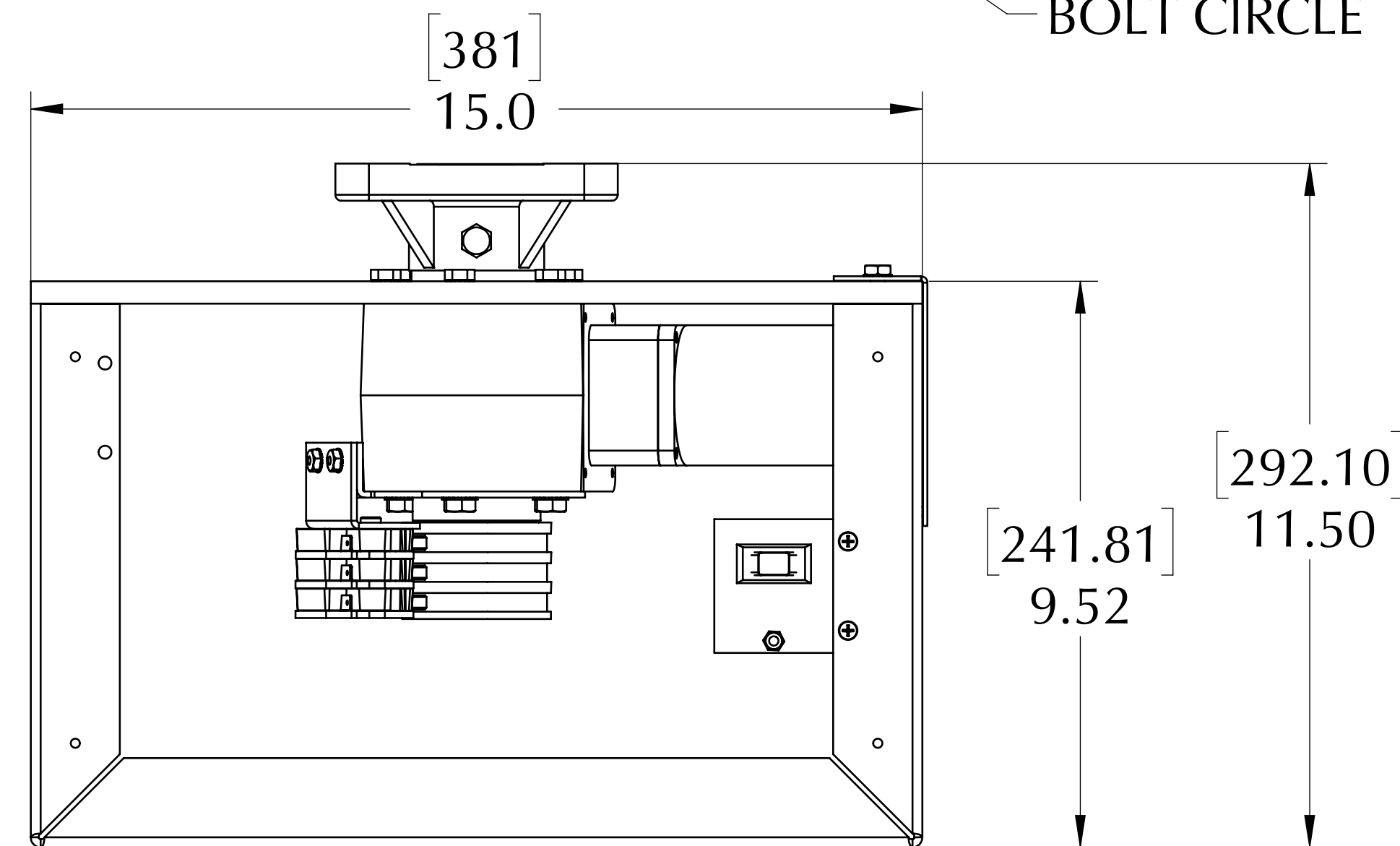
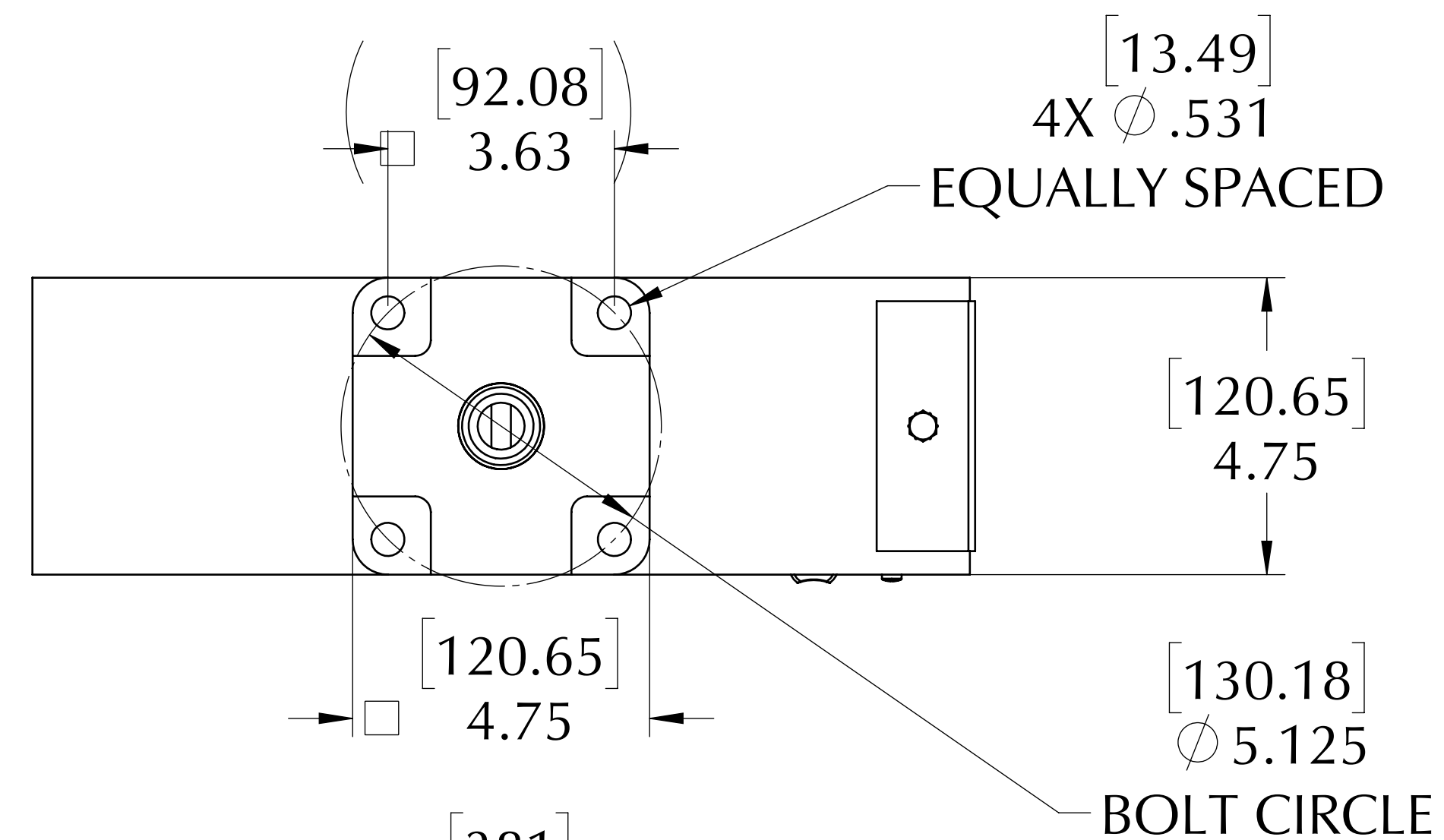

Dynapac Rotating Company Inc.
 338 Hansen Ave., Salt Lake City, UT 84115
 Phone: 801-485-2221 • Fax: 801-485-2254
 email: info@dynapacrotating.com • www.dynapacrotating.com