

COVER TO SHEILD MOVING PARTS

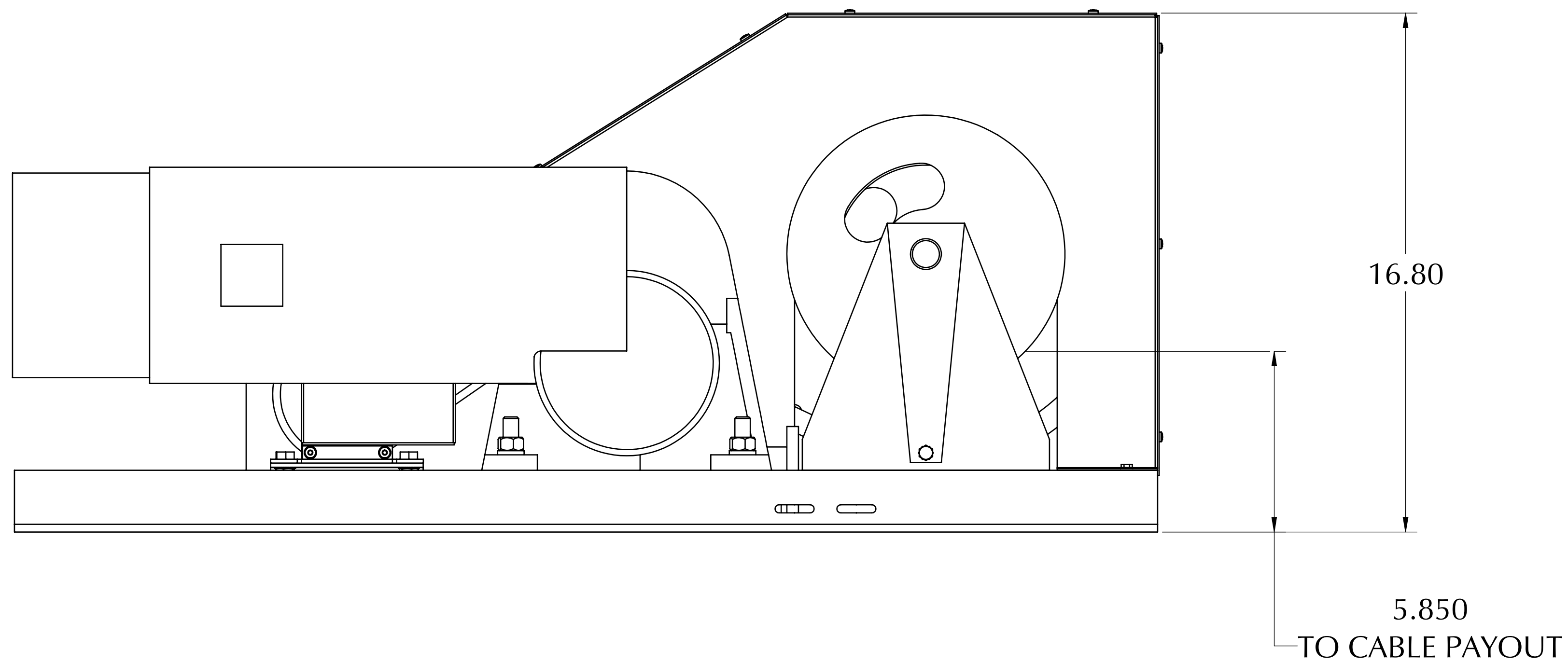
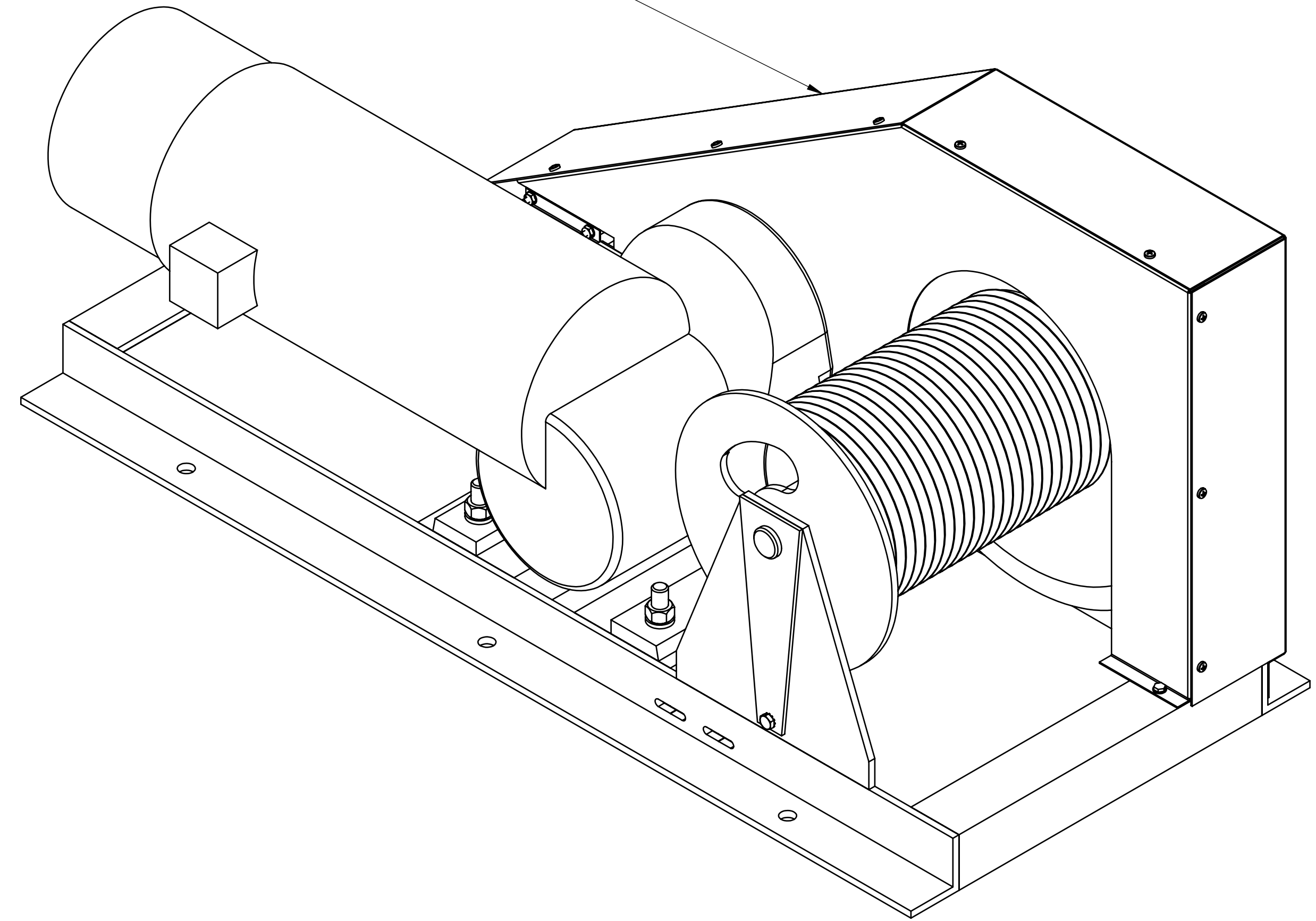

SPECIFICATIONS:

- HANGING WEIGHT CAPACITY: 2000 LBS
- HOIST UNIT WEIGHT: 225 LBS
- ELECTRICAL INPUT: 200-240VAC, 1 PHASE, 16A, 50-60HZ
- LIFT CABLE SPEC: \varnothing 3/8" STAINLESS STEEL NON ROTATING WIRE ROPE, 19X7 WEAVE, 11,000LB BREAKING STRENGTH, 2200LB RATED STRENGTH
- INCLUDES ADJUSTABLE UPPER AND LOWER LIMIT SWITCHES
- INCLUDES 16" X 16" ELECTRICAL CONTROL BOX, MOUNTED WITHIN 6' OF HOIST

2000 lb LIFTING WINCH			
UNLESS OTHERWISE SPECIFIED DIMENSIONS ARE IN INCHES	APPROVALS	DATE	DYNAPAC ROTATING CO. SALT LAKE CITY, UTAH
	DRAWN AMMON ENCE	2/18/09	
TOLERANCES:	CHECKED		
FRACTIONAL \pm 1/32			
ANGULAR \pm 2"			
DECIMAL .XX \pm .010 .XXX \pm .010	ENG. APPR.		
MATERIAL	APPLICATION	SIZE	DWG. NO.
FINISH	NEXT ASSY	D	189002
	FINAL ASSY	SCALE: 1:3	REV +02
© COPYRIGHT DYNAPAC ROTATING CO., INC. ALL RIGHTS RESERVED			SHEET 1 OF 2