

Model IR-600

(Part # 156002 021HD)

The IR-600 turntable has been designed with reliability, stability and ruggedness in mind. Precision nylon tapered roller wheels provide a quiet rolling surface on a machined race. A safety torque relief clutch provides assurance that the turntable will slip under overload conditions, rather than damage the motor. The three-wire grounded, switched input cord makes installation simple. The sizable 16-inch turntable provides a stable mounting surface that gives ACTION ATTRACTION to any display need.

WEIGHT CAPACITY.....	600 lbs
MAX. ALLOWABLE SIZE.....	6' X 6'
HANGING WEIGHT CAPACITY.....	none
RPM'S AVAILABLE.....	1/2, 1, 2 (standard), 3, 4, or 6
TORQUE OUTPUT @ 2 RPM.....	45 In-lbs
MOTOR DRAW(@115 Volts).....	0.1A (12 watts)
POWER CORD.....	10' Grounded with inline switch
SAFETY CLUTCH.....	Standard feature
MAIN DRIVE.....	Spur Gear
SHIPPING WEIGHT.....	21 lbs

MOTOR WIRE DIAGRAM

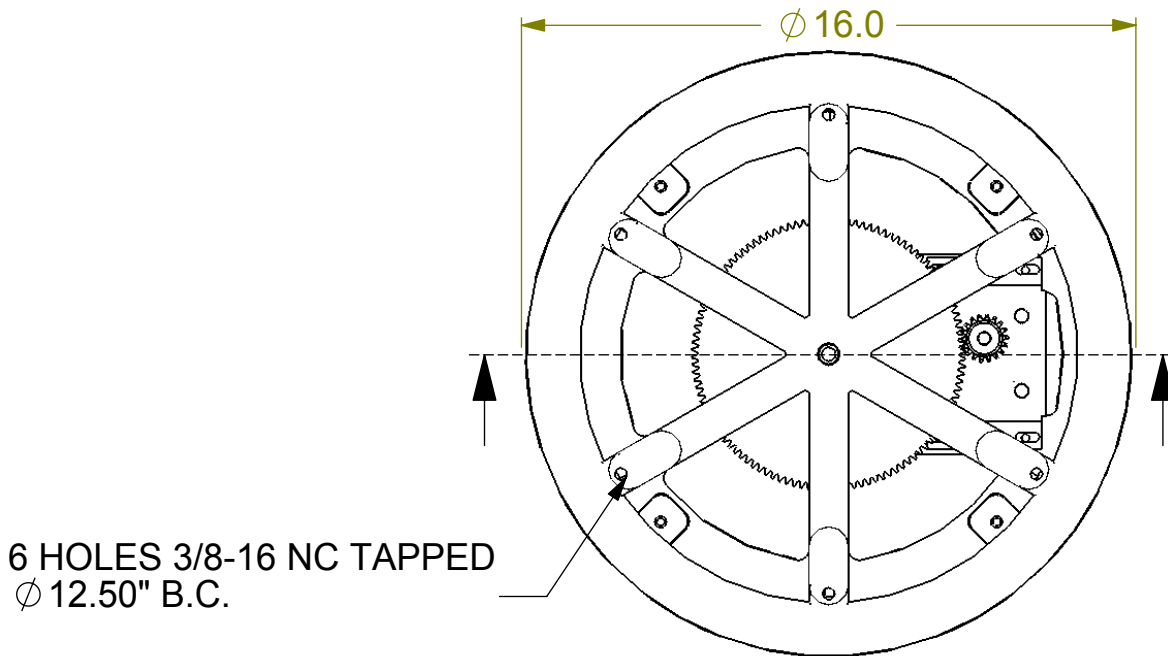
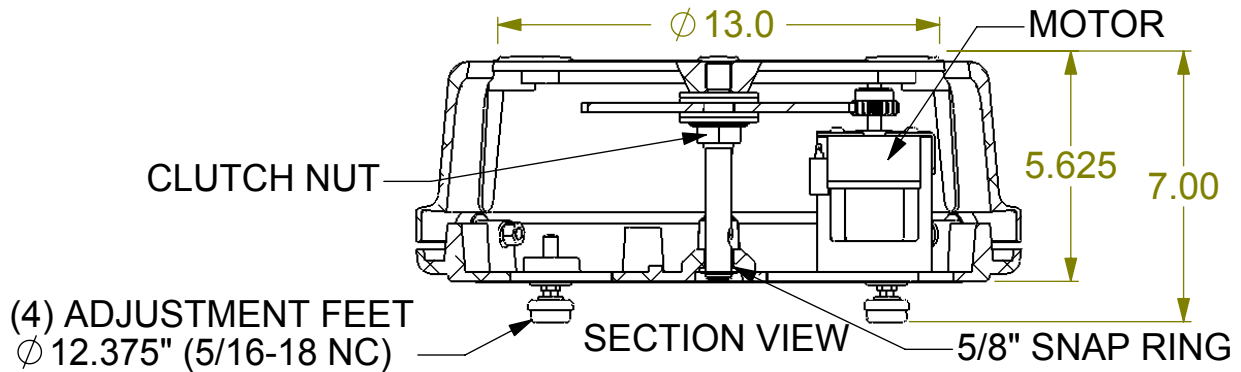
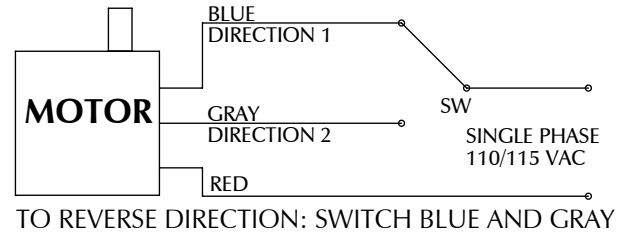

DYNAPAC ROTATING COMPANY, INC.

338 Hansen Ave. • Salt Lake City, Utah 84115-5115
 Phone 800-657-2650 • 801-485-2221 • Fax 801-485-2254
 email: info@dynapacrotating.com • www.dynapacrotating.com