

# Model IR-600

(Part # 156001 221HD)

The IR-600 turntable has been designed with reliability, stability and ruggedness in mind. Precision nylon tapered roller wheels provide a quiet rolling surface on a machined race. A safety torque relief clutch provides assurance that the turntable will slip under overload conditions, rather than damage the motor. The three-wire grounded, switched input cord makes installation simple. The sizable 16-inch turntable provides a stable mounting surface that gives ACTION ATTRACTION to any display need.

WEIGHT CAPACITY.....	600 lbs
MAX. ALLOWABLE SIZE.....	5' X 5'
HANGING WEIGHT CAPACITY.....	none
RPM'S AVAILABLE.....	1, 2 (standard), 3, 4, or 6
COLLECTOR RING CAPACITY*.....	10A @ 115V
TORQUE OUTPUT @ 2 RPM.....	45 In-lbs
MOTOR DRAW(@115 Volts).....	0.1A (12 watts)
POWER CORD.....	10' grounded with inline switch
SAFETY CLUTCH.....	Standard feature
MAIN DRIVE.....	Spur Gear
SHIPPING WEIGHT.....	23 lbs

## MOTOR WIRE DIAGRAM

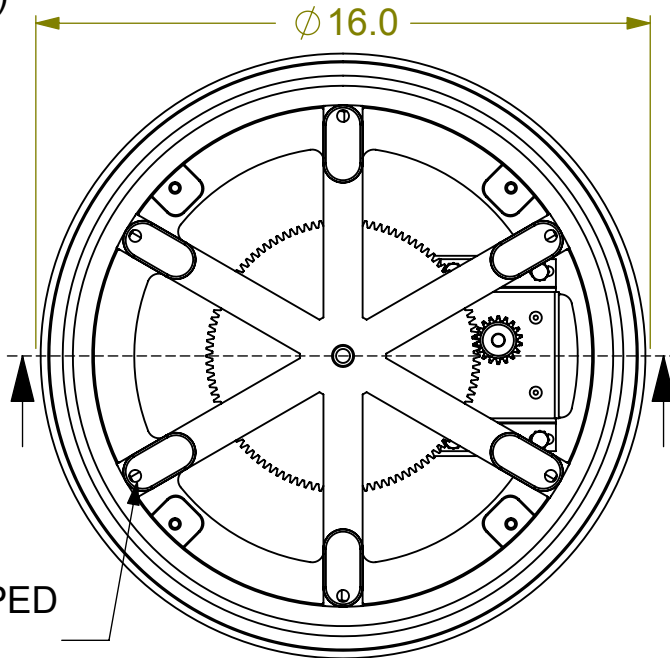
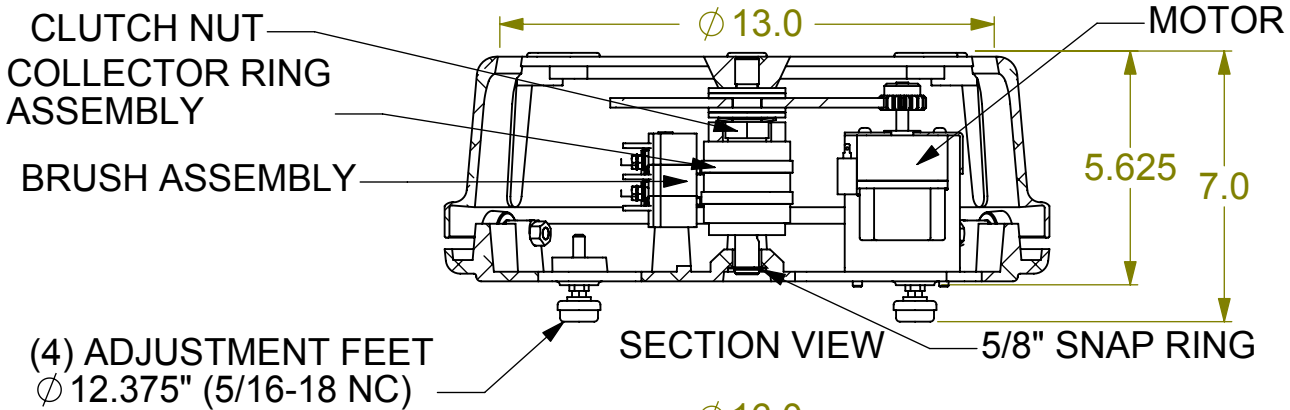
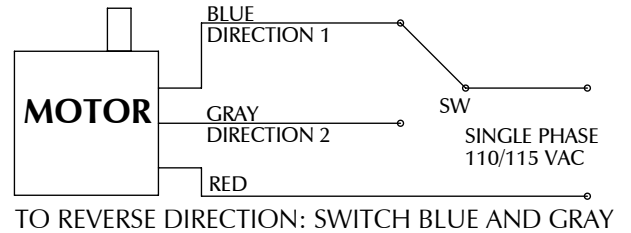

6 HOLES 3/8-16 NC TAPPED  
 $\phi$  12.5" B.C.



## DYNAPAC ROTATING COMPANY, INC.

338 Hansen Ave. • Salt Lake City, Utah 84115-5115  
 Phone 800-657-2650 • 801-485-2221 • Fax 801-485-2254  
 email: [info@dynapacrotating.com](mailto:info@dynapacrotating.com) • [www.dynapacrotating.com](http://www.dynapacrotating.com)