

# Model IG-5

(Part # 155001 321HD)

Dependable performance, durable construction and safety conscious. Features a unique torque relief mechanism that slips harmlessly if turning motion is obstructed to prevent personal injury and keep motor from burning out. Great for small indoor signs or displays.

WEIGHT CAPACITY.....	400 lbs.
MAX. ALLOWABLE SIZE.....	5' X 5'
HANGING WEIGHT CAPACITY.....	300 lbs.
RPM'S AVAILABLE.....	1/2, 1, 2 (standard), 3, 4, or 6
TORQUE OUTPUT @ 2 RPM.....	24 In-lbs
MOTOR DRAW(@115 Volts).....	0.1A (12 watts)
SAFETY CLUTCH.....	Standard feature
MAIN DRIVE.....	Gearhead
SHIPPING WEIGHT.....	12 lbs.

## WIRE DIAGRAM

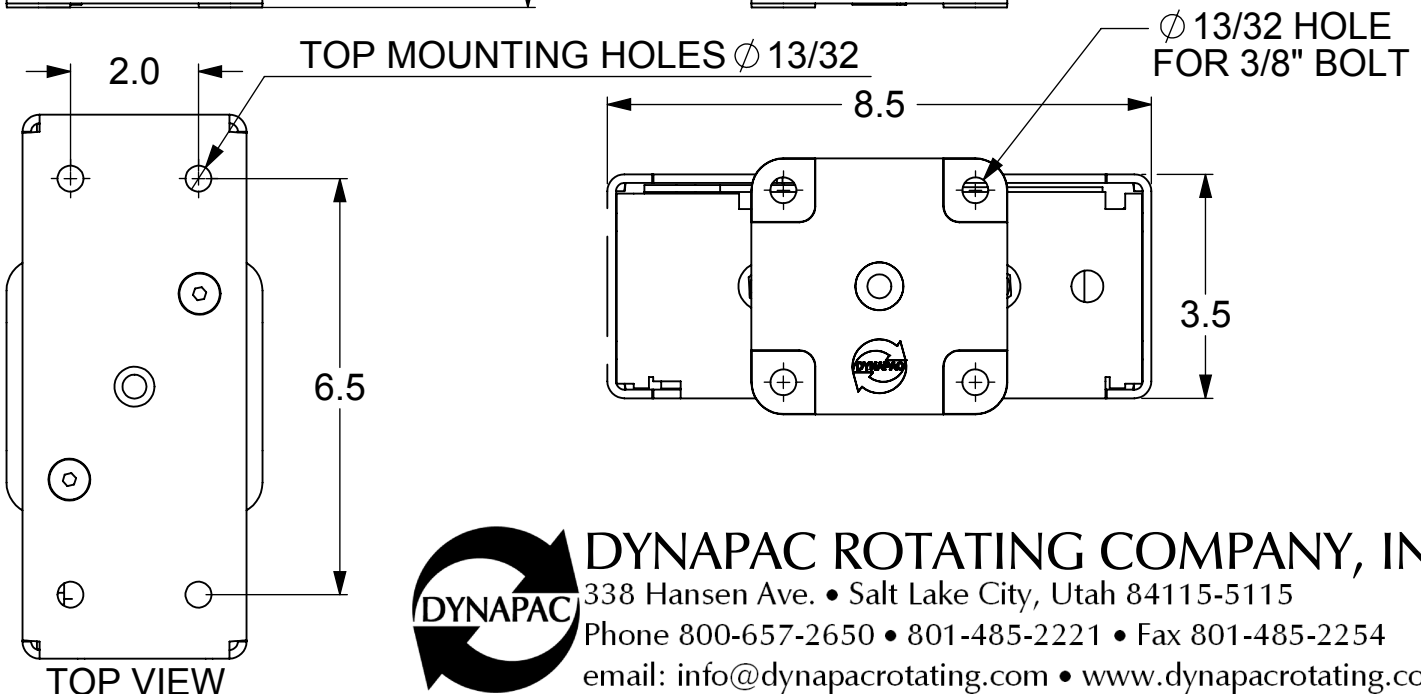
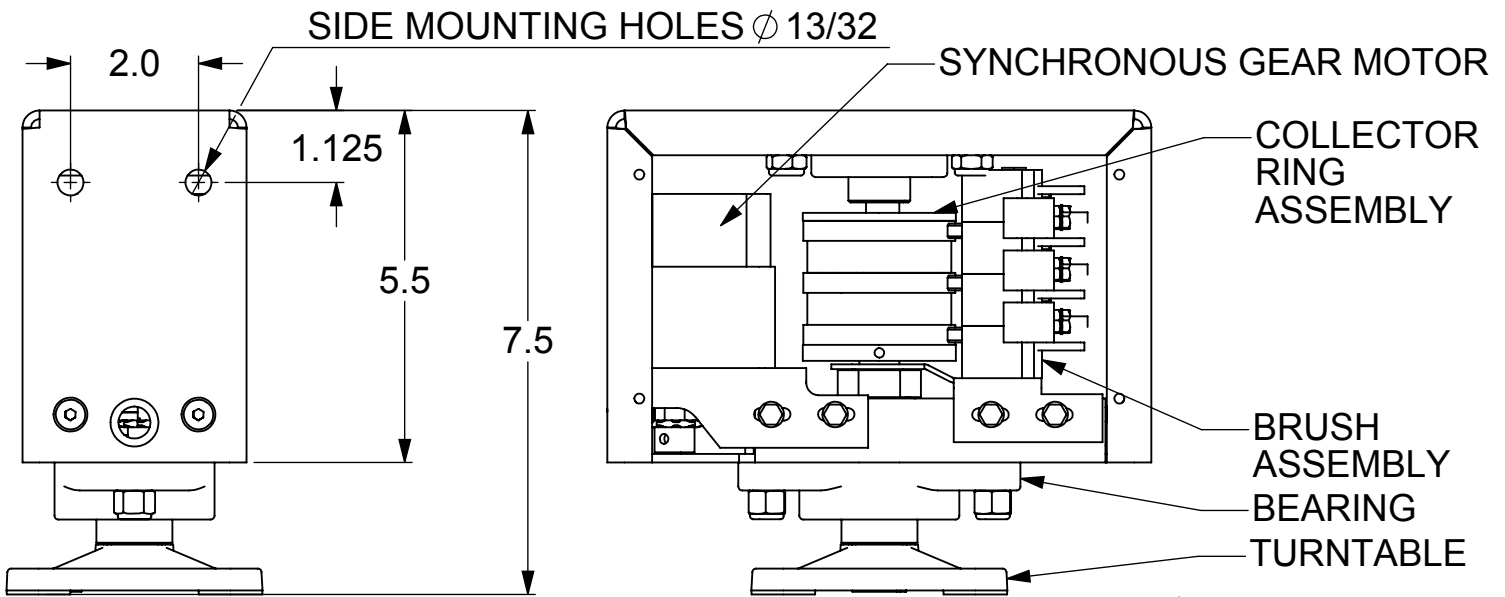
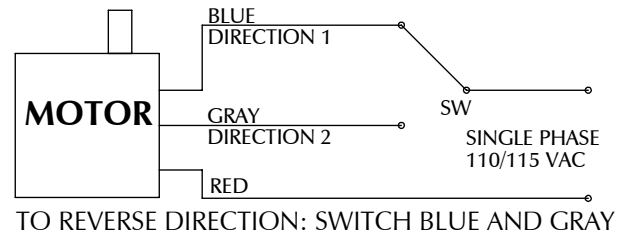

**DYNAPAC ROTATING COMPANY, INC.**

338 Hansen Ave. • Salt Lake City, Utah 84115-5115

Phone 800-657-2650 • 801-485-2221 • Fax 801-485-2254

email: [info@dynapacrotating.com](mailto:info@dynapacrotating.com) • [www.dynapacrotating.com](http://www.dynapacrotating.com)