

Model IG-2

(Part # 154001 221HD)

Dependable performance, durable construction and safety conscious. Features a unique torque relief mechanism that slips harmlessly if turning motion is obstructed to prevent personal injury and keep motor from burning out. Great for small indoor signs or displays.

| | |
|------------------------------|----------------------------------|
| WEIGHT CAPACITY..... | 150 lbs |
| MAX. ALLOWABLE SIZE..... | 3' X 3' |
| HANGING WEIGHT CAPACITY..... | 100 lbs |
| RPM'S AVAILABLE..... | 1/2, 1, 2 (standard), 3, 4, or 6 |
| TORQUE OUTPUT @ 2 RPM..... | 24 In-lbs |
| COLLECTOR RING CAPACITY..... | 10A |
| MOTOR DRAW(@115 Volts)..... | 0.1A (12 watts) |
| SAFETY CLUTCH..... | Standard feature |
| MAIN DRIVE..... | Gearhead |
| SHIPPING WEIGHT..... | 6 lbs |

WIRE DIAGRAM

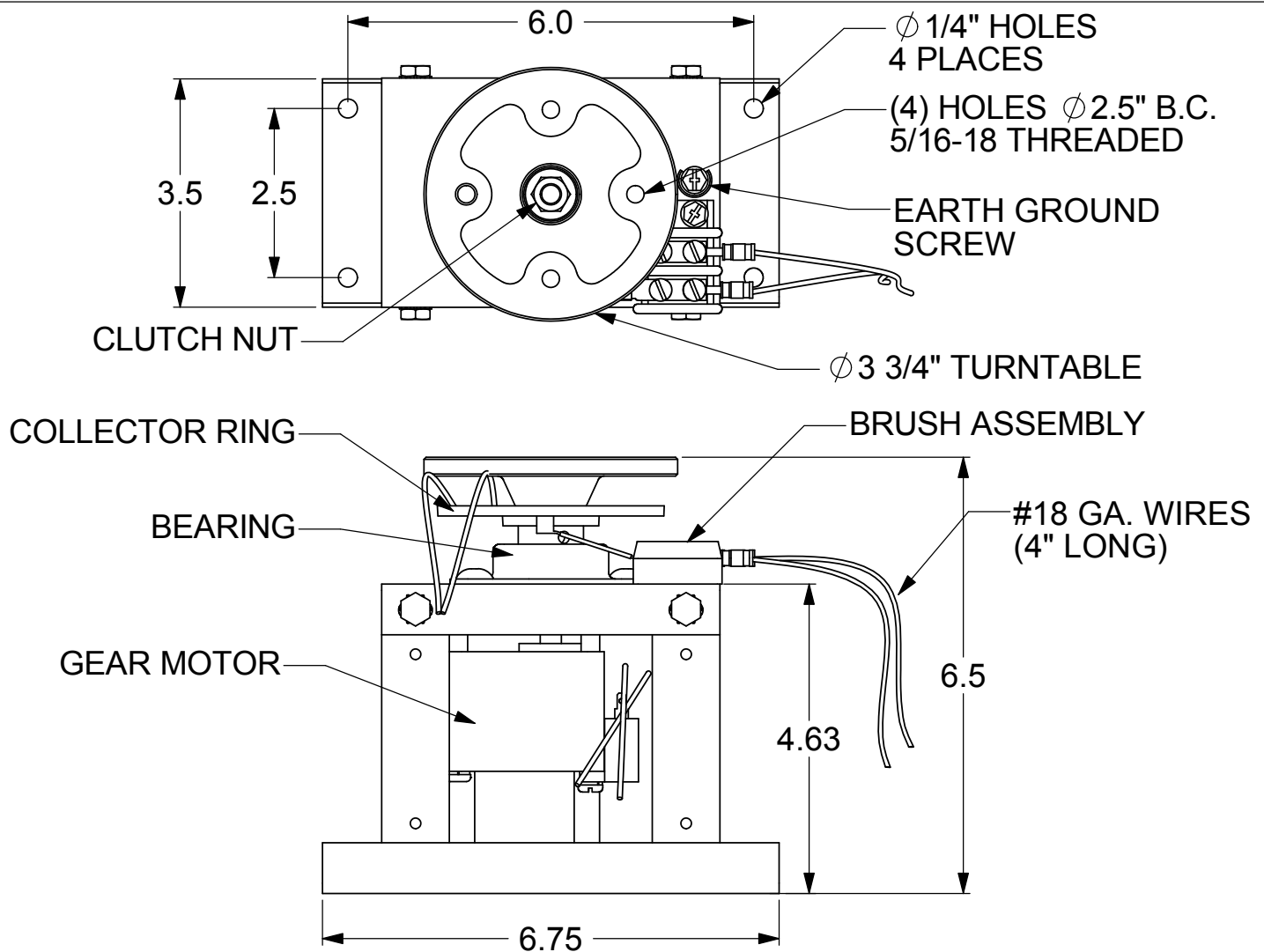
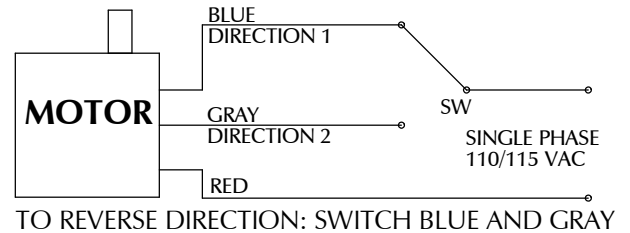

DYNAPAC ROTATING COMPANY, INC.

338 Hansen Ave. • Salt Lake City, Utah 84115-5115
 Phone 800-657-2650 • 801-485-2221 • Fax 801-485-2254
 email: info@dynapacrotating.com • www.dynapacrotating.com