

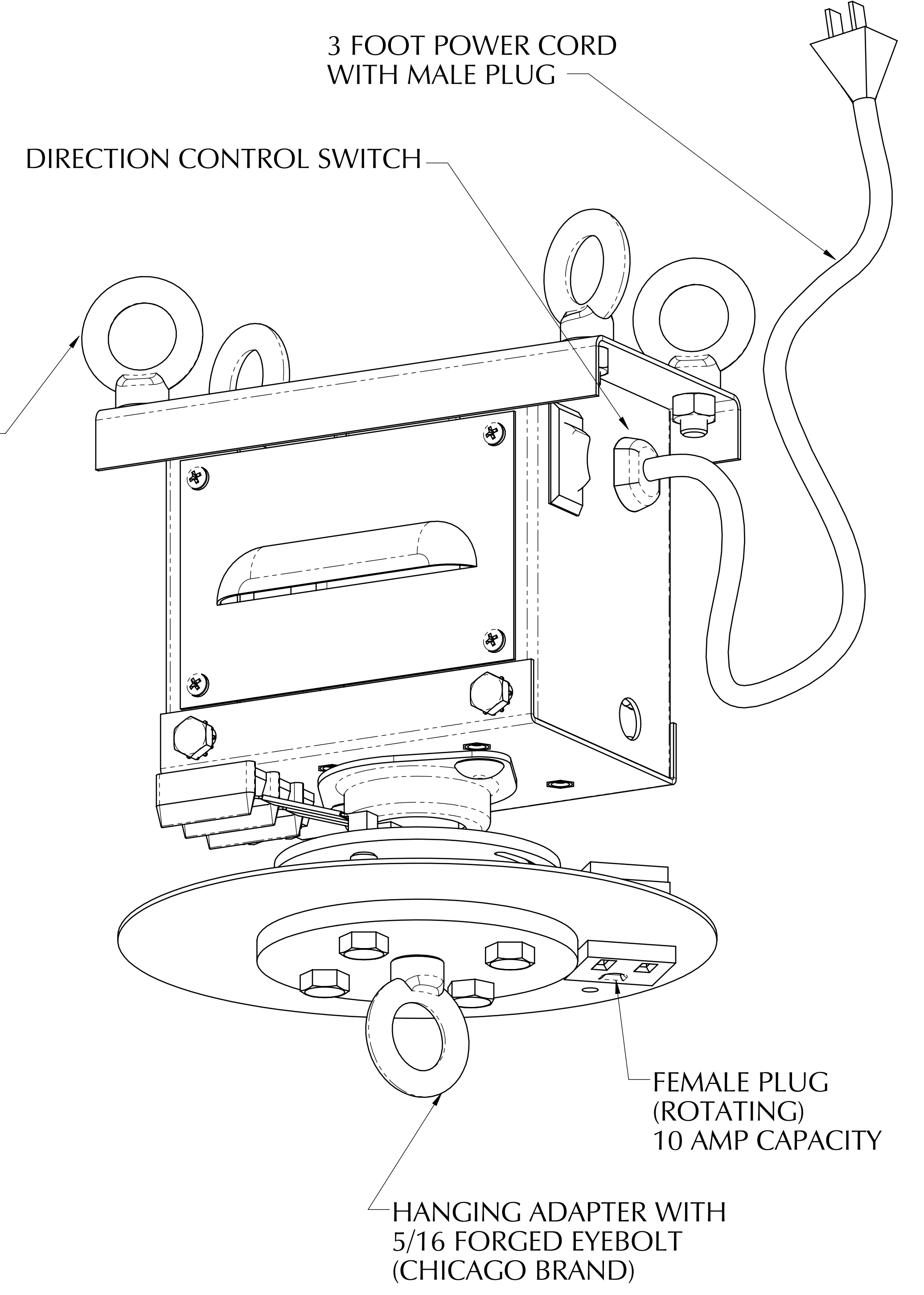

REVISIONS			
REV.	DESCRIPTION	DATE	APPROVED

MODEL IG-2 HANGING ROTATOR PART # 154001 221HANG

HANGING WEIGHT CAPACITY: 100 LBS.
 AVAILABLE RPM SPEEDS: 1, 2(STD), 3, 4, 6
 MOTOR DRAW: 0.1A (12W)
 SAFETY CLUTCH: YES
 OUTPUT POWER PLUG CAPACITY: 10 AMP

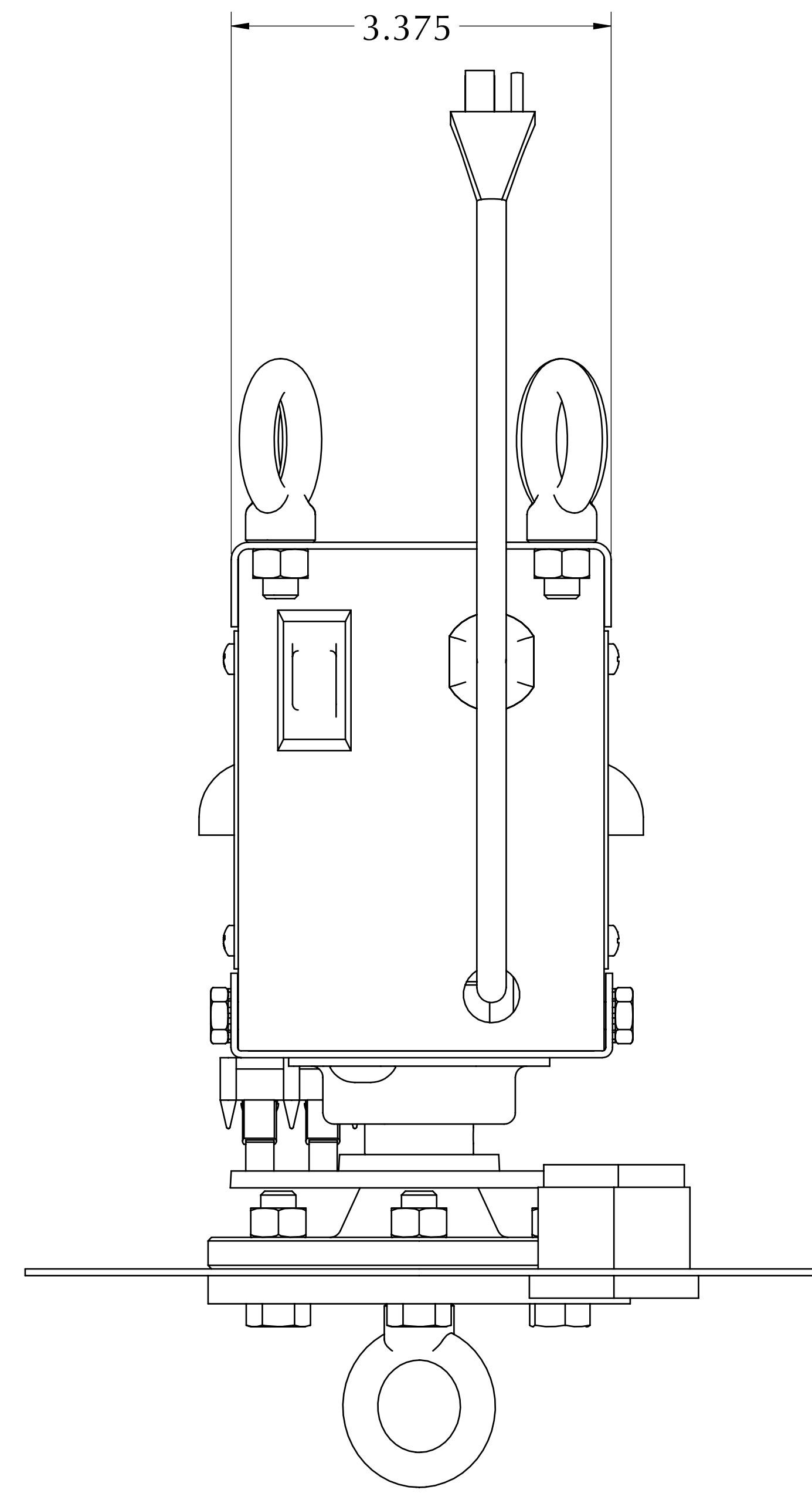
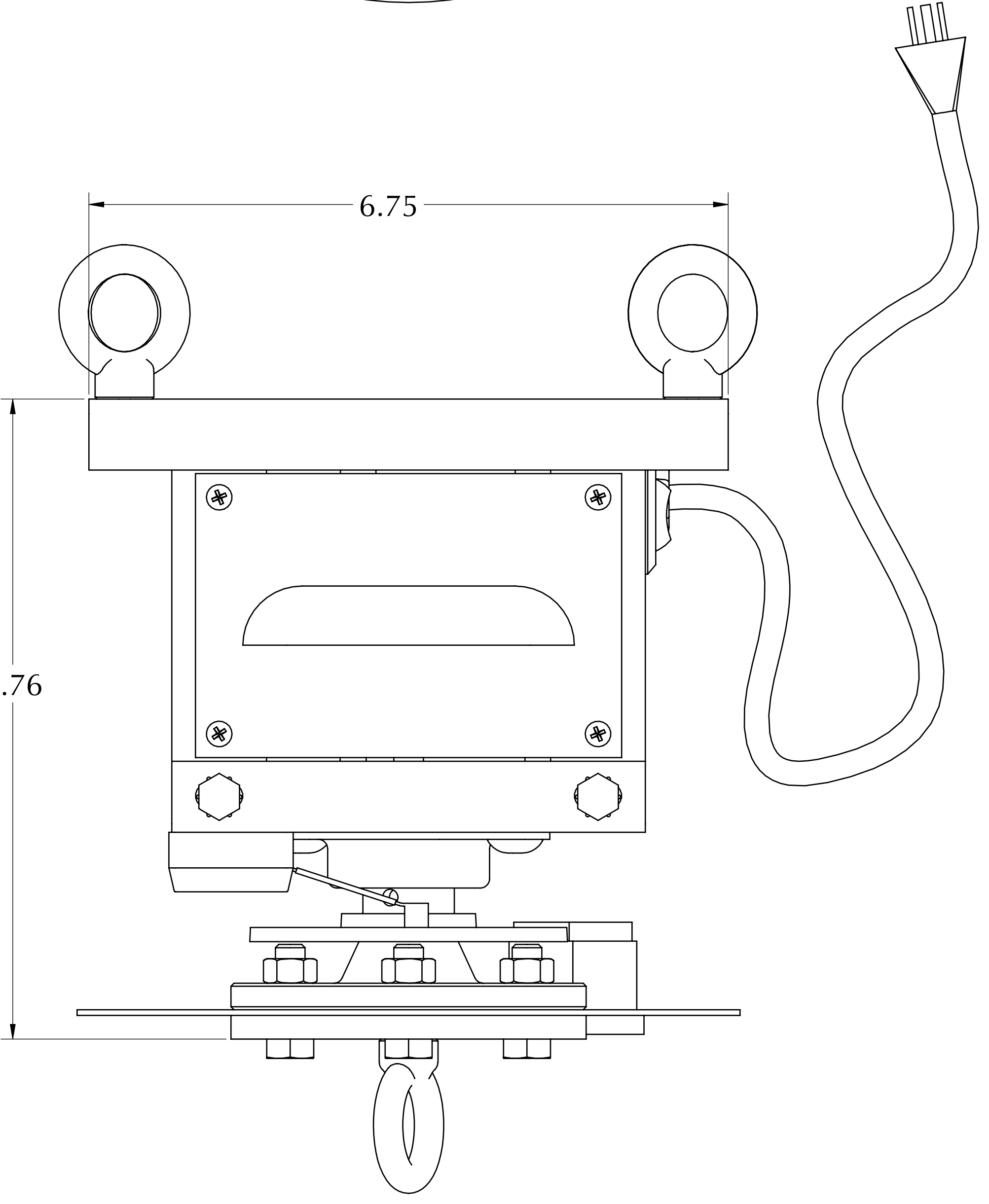
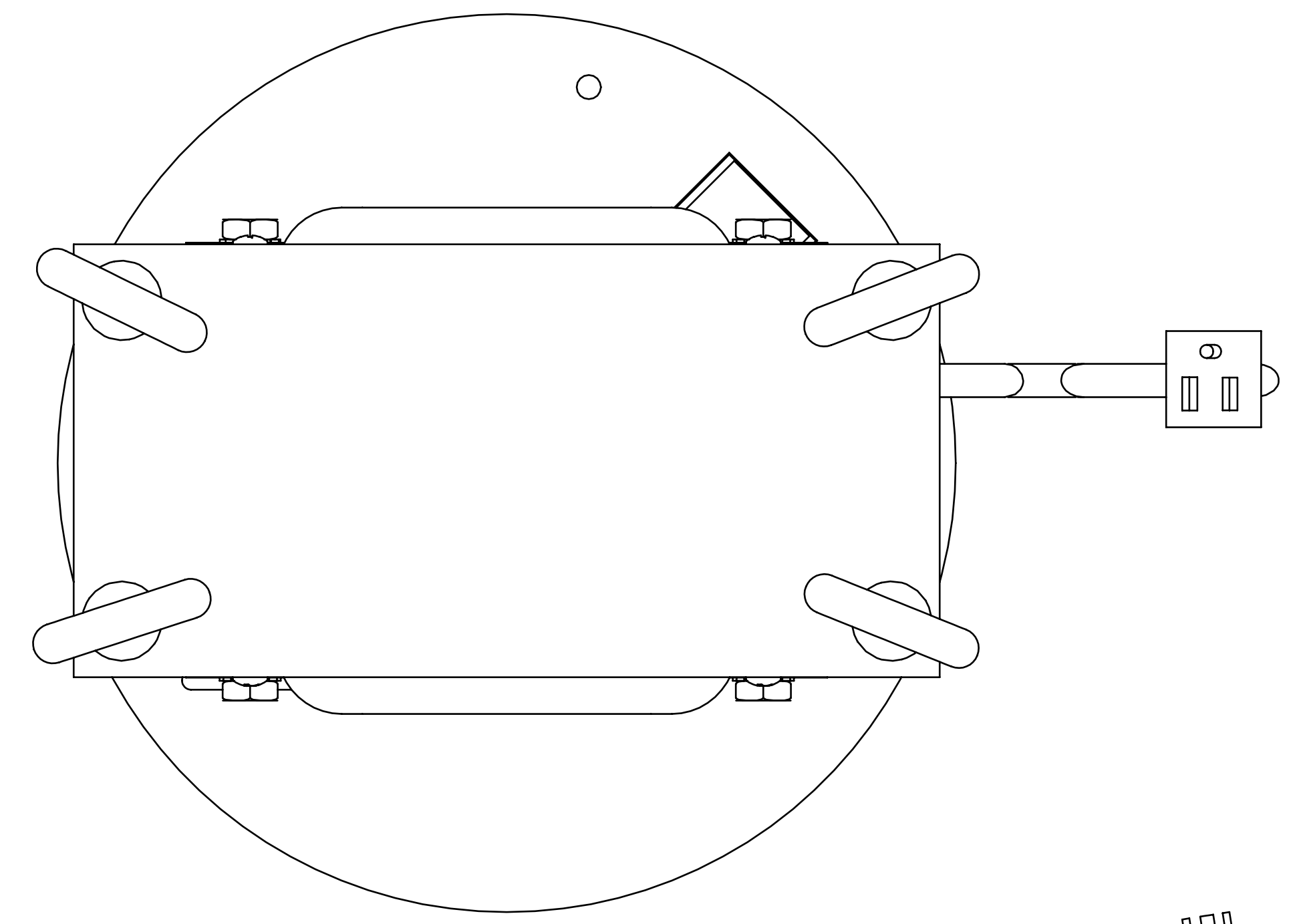

- ACCESSORIES INCLUDED**
- 537140 1 HANGING ADAPTER 5/16" EYEBOLT
 - 660200 FORGED EYEBOLTS IN FRAME (4 EA.)
 - 537102 LOUVERED SHEET METAL COVERS (2 EA.)
 - CORDSET 16/3 SJO CORD WITH MALE PLUG (3 FOOT)
 - 639287 FEMALE PLUG
 - G4X848 DIRECTION CONTROL SWITCH (C.W. - OFF - C.C.W)

UNLESS OTHERWISE SPECIFIED DIMENSIONS ARE IN INCHES	APPROVALS	DATE	DYNAPAC ROTATING CO. SALT LAKE CITY, UTAH
	DRAWN		
TOLERANCES:	CHECKED		
FRACTIONAL ± 1/32	ENG APPR.		
ANGULAR ± 2°			SIZE DWG. NO. REV 154001 221HANG 01
DECIMAL .XX ± 0.00 .XXX ± 0.010			SCALE: 1:1 SHEET 1 OF 1

PROPRIETARY AND CONFIDENTIAL
 THE INFORMATION CONTAINED IN THIS DRAWING IS THE SOLE PROPERTY OF DYNAPAC ROTATING CO., INC. ANY REPLICATION IN PART OR AS A WHOLE WITHOUT THE WRITTEN PERMISSION OF DYNAPAC ROTATING CO., INC. IS PROHIBITED.
 © COPYRIGHT DYNAPAC ROTATING CO., INC. ALL RIGHTS RESERVED