

Model IG-4

(Part # 150001 321HD)

A compact yet powerful rotator gives ACTION ATTRACTION to any indoor sign or display. Torque relief mechanism slips harmlessly if turning motion is obstructed. Extreme versatility allows installation on ceiling, floor, wall or inside mount.

WEIGHT CAPACITY.....	300 lbs
MAX ALLOWABLE SIZE.....	4' X 4'
HANGING WEIGHT CAPACITY.....	200 lbs
RPM'S AVAILABLE.....	1, 2 (standard), 3, 4, or 6
TORQUE OUTPUT @ 2 RPM.....	39 In-lbs
COLLECTOR RING CAPACITY*.....	15A
MOTOR DRAW (@ 115 Volts).....	0.1A (12 watts)
SAFETY CLUTCH.....	Standard feature
MAIN DRIVE.....	Nonslip timing belt
SHIPPING WEIGHT.....	12 lbs

WIRE DIAGRAM

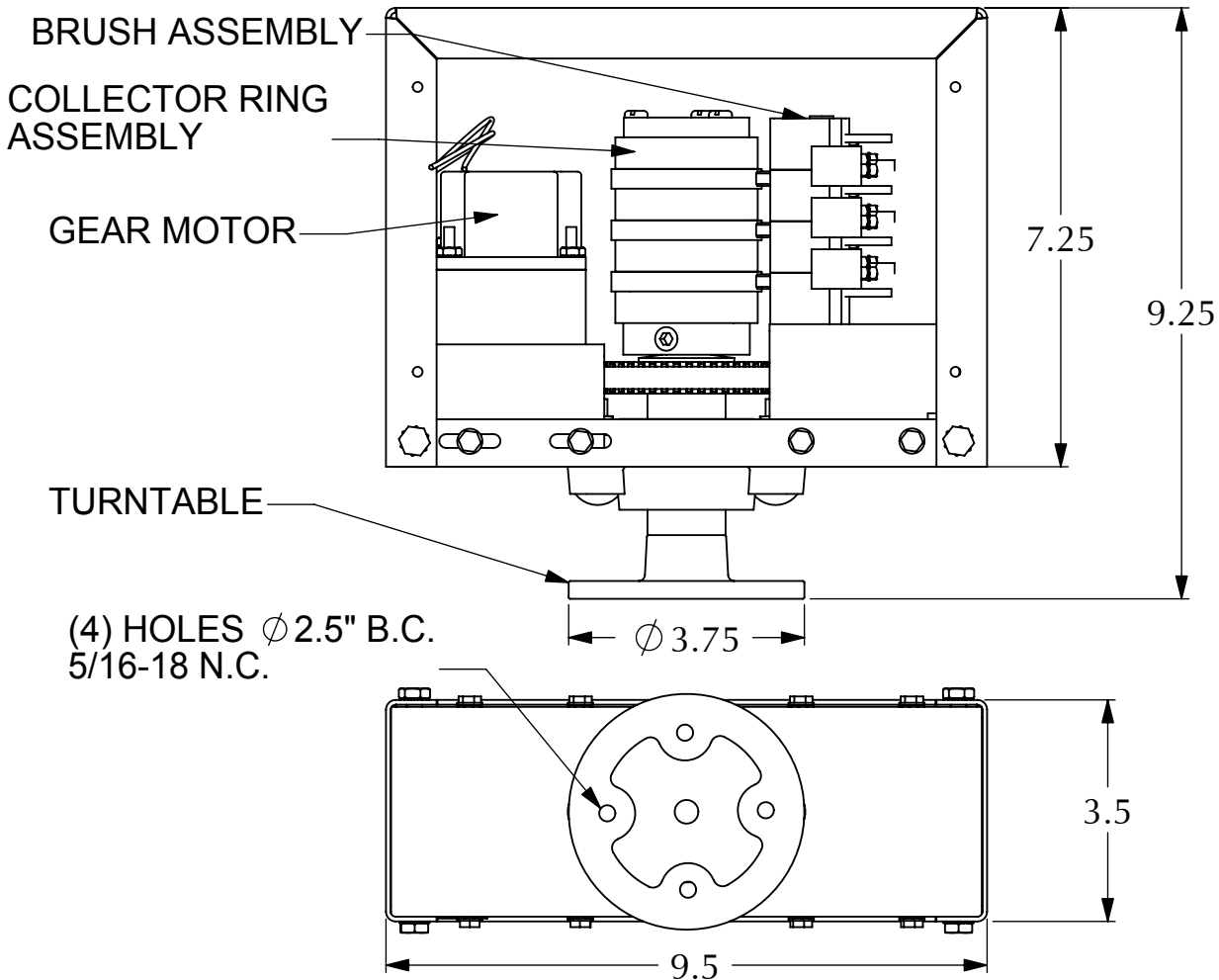
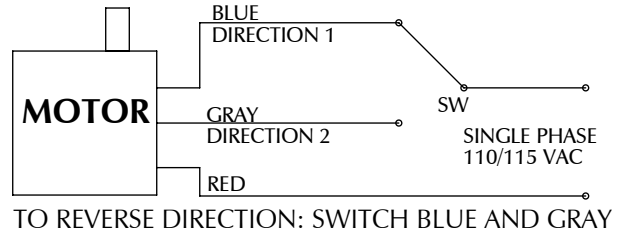

DYNAPAC ROTATING COMPANY, INC.

338 Hansen Ave. • Salt Lake City, Utah 84115-5115
 Phone 800-657-2650 • 801-485-2221 • Fax 801-485-2254
 email: info@dynamacrotating.com • www.dynamacrotating.com

*Higher amp loads available upon request