

M-10 HANG

(Part # 144118)

Hanging rotator that is designed for small, lightweight loads weighing less than 10 lbs. This unit includes a rotating power outlet for powered lights or devices in your rotating display. Comes with a 6 foot long power cord.

WEIGHT CAPACITY.....	10 lbs.
MAX. HANGING DIAMETER.....	Ø 3 ft.
HANGING WEIGHT CAPACITY.....	10 lbs.
AMP LOAD LIMIT (2 RING COLLECTOR RING).....	10 Amps
RPM (ROTATING SPEED).....	2.5 RPM
TORQUE OUTPUT @ 2 RPM.....	3.5 In-lbs
MOTOR DRAW(@115 Volts).....	0.02A (3 watts)
SAFETY CLUTCH.....	Standard feature
MAIN DRIVE.....	Gearhead
SHIPPING WEIGHT.....	3 lbs.

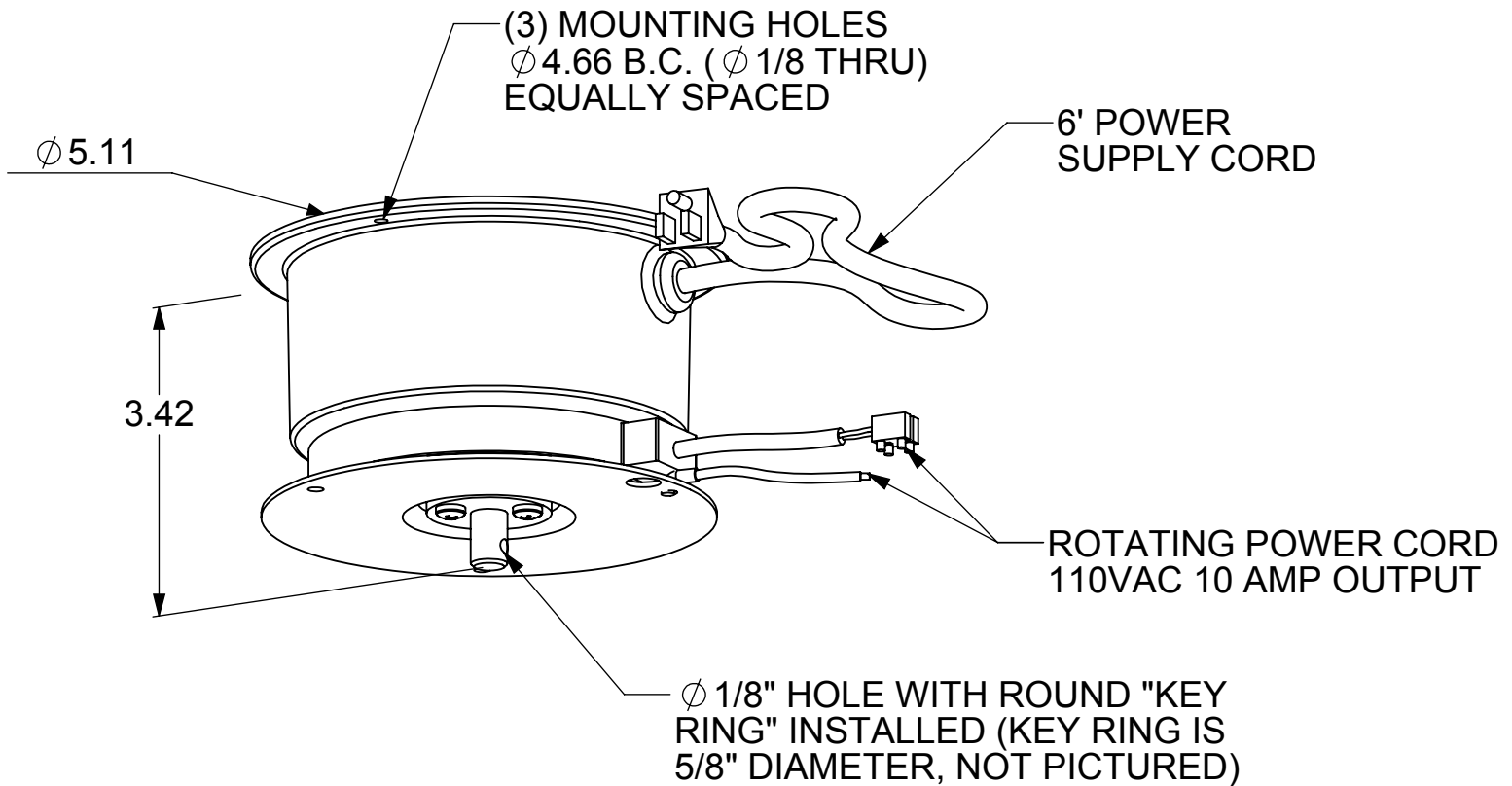

DYNAPAC ROTATING COMPANY, INC.

338 Hansen Ave. • Salt Lake City, Utah 84115-5115

Phone 800-657-2650 • 801-485-2221 • Fax 801-485-2254

email: info@dynapacrotating.com • www.dynapacrotating.com