

# Model L-200C

(Part #136014 321)

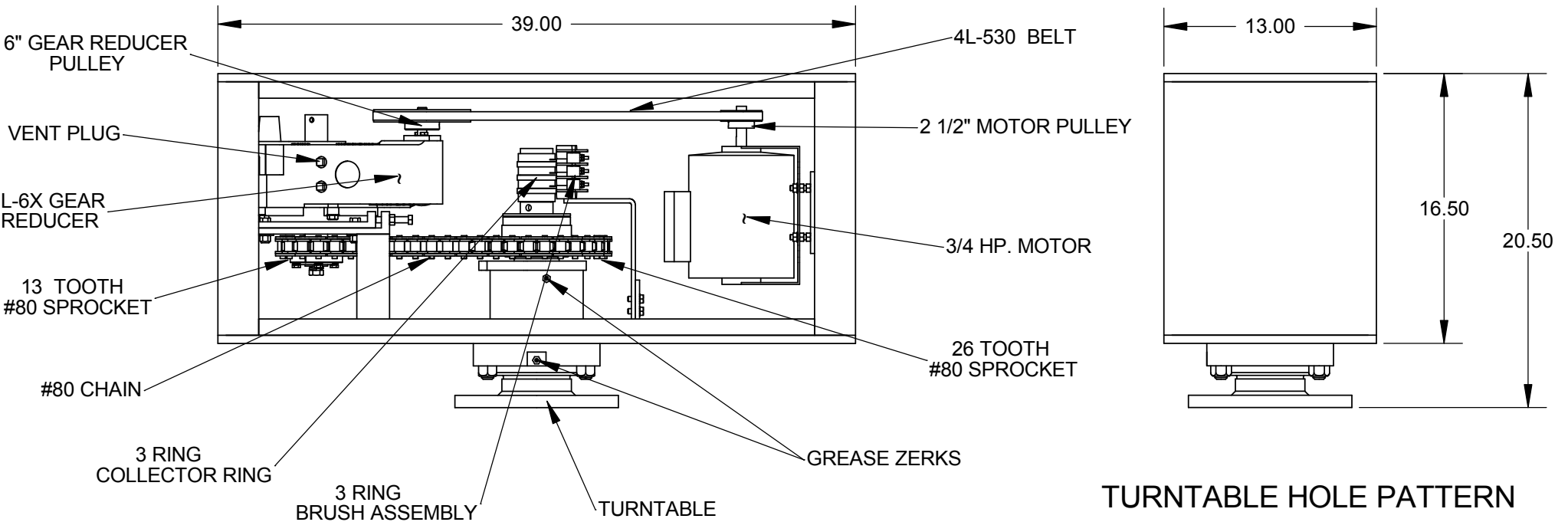

## TURNTABLE HOLE PATTERN

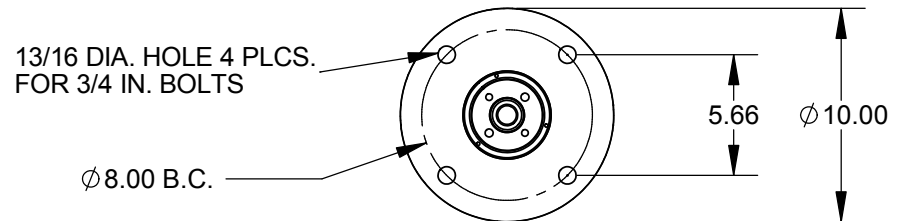

- MAX. WEIGHT CAPACITY.....4200 lbs.
- MAX. TORQUE CAPACITY.....800 lbs.
- MAX. SHEAR LOAD.....7500 lbs.
- MAX. BENDING MOMENT.....9000 lbs.
- MOTOR.....3/4 hp.
- MOTOR DRAW.....6.5 amps @ 230 volts  
13.3 amps @ 115 volts
- RPM AVAILABLE.....1, 2 (standard)
- MAX AMP LOAD ON COLLECTOR RING.....15 amps @ 115 volts

For signs requiring a lot of torque - up to 800 ft. lbs. These units have filled a great need in turning large signs with the unit positioned inside the sign. Larger collector ring capacity is available on request.



Dynamapac Rotating Co.

**SolidWorks Detached drawing - Out-of-Sync Print**

Phone (801) 485-2221 - Fax (801) 485-2254

www.dynamapacrotating.com - email: dynamapac@netutah.net