

Model L-350

(Part #136003 341)

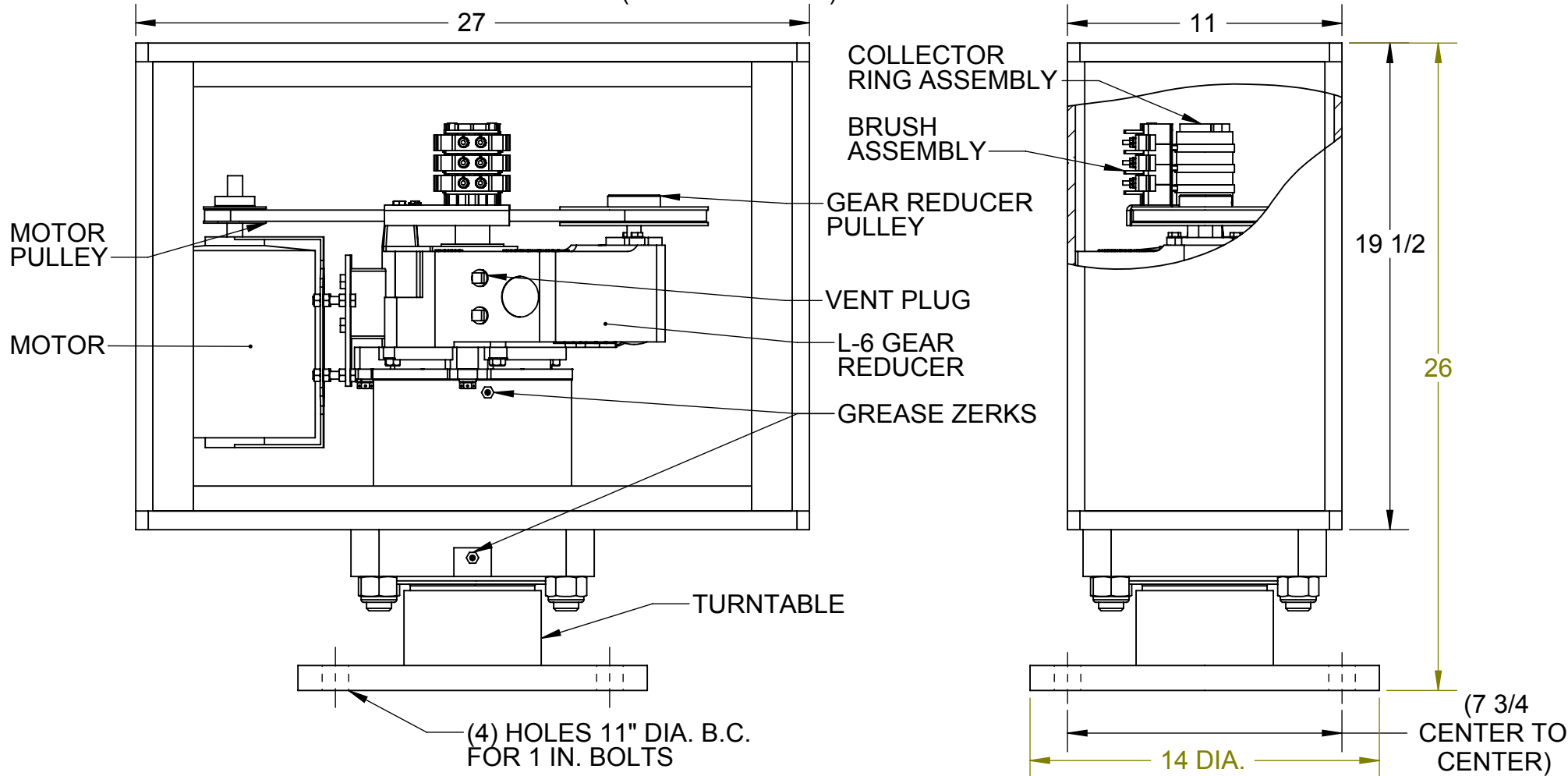

MAX. WEIGHT CAPACITY.....8400 lbs.
 MAX. TORQUE CAPACITY.....350 ft. lbs.
 MAX. SHEAR LOAD.....9000 lbs.
 MAX. BENDING LOAD.....19000 ft. lbs.
 AMP LOAD LIMIT*.....15A

(3 ring collector ring)
 MOTOR.....3/4 hp.
 MOTOR DRAW.....12A @ 115 VAC
 6A @ 230 VAC
 RPM'S AVAILABLE.....1, 2, 3, 4 (standard)

*Higher amp loads available upon request.

The most powerful stock series of rotators made by Dynapac. No wind is too strong for these tough units to handle! Easily produces up to 350 ft. lbs. of torque to power gigantic signs with little effort.



Dynapac Rotating Company, Inc.

338 Hansen Ave. • Salt Lake City, UT 84115-5115
 Phone 800-657-2650 • 801-485-2221 • Fax 801-485-2254
 email: info@dynapacrotating.com
 www.dynapacrotating.com