

# Model K-80

(Part # 135050 361)

The K-36 can easily and reliably power larger displays. This rotator provides additional torque up to 130 ft-lbs to turn signs and exhibits requiring high torque.

WEIGHT CAPACITY.....	2000 lbs
MAX. ALLOWABLE SIZE.....	Contact Dynapac
HANGING WEIGHT CAPACITY.....	2000 lbs
RPM'S AVAILABLE.....	1, 2, 3, 4, or 6
TORQUE OUTPUT @ 2 RPM.....	130 ft-lbs
MAX. SHEAR LOAD.....	2430 lbs
MAX. BENDING LOAD.....	2495 ft-lbs
COLLECTOR RING CAPACITY*.....	15A @ 115V
MOTOR DRAW(@115 Volts).....	5.1A (587 watts)
SAFETY CLUTCH.....	Standard feature
MAIN DRIVE.....	Gear Reducer
SHIPPING WEIGHT.....	137 lbs

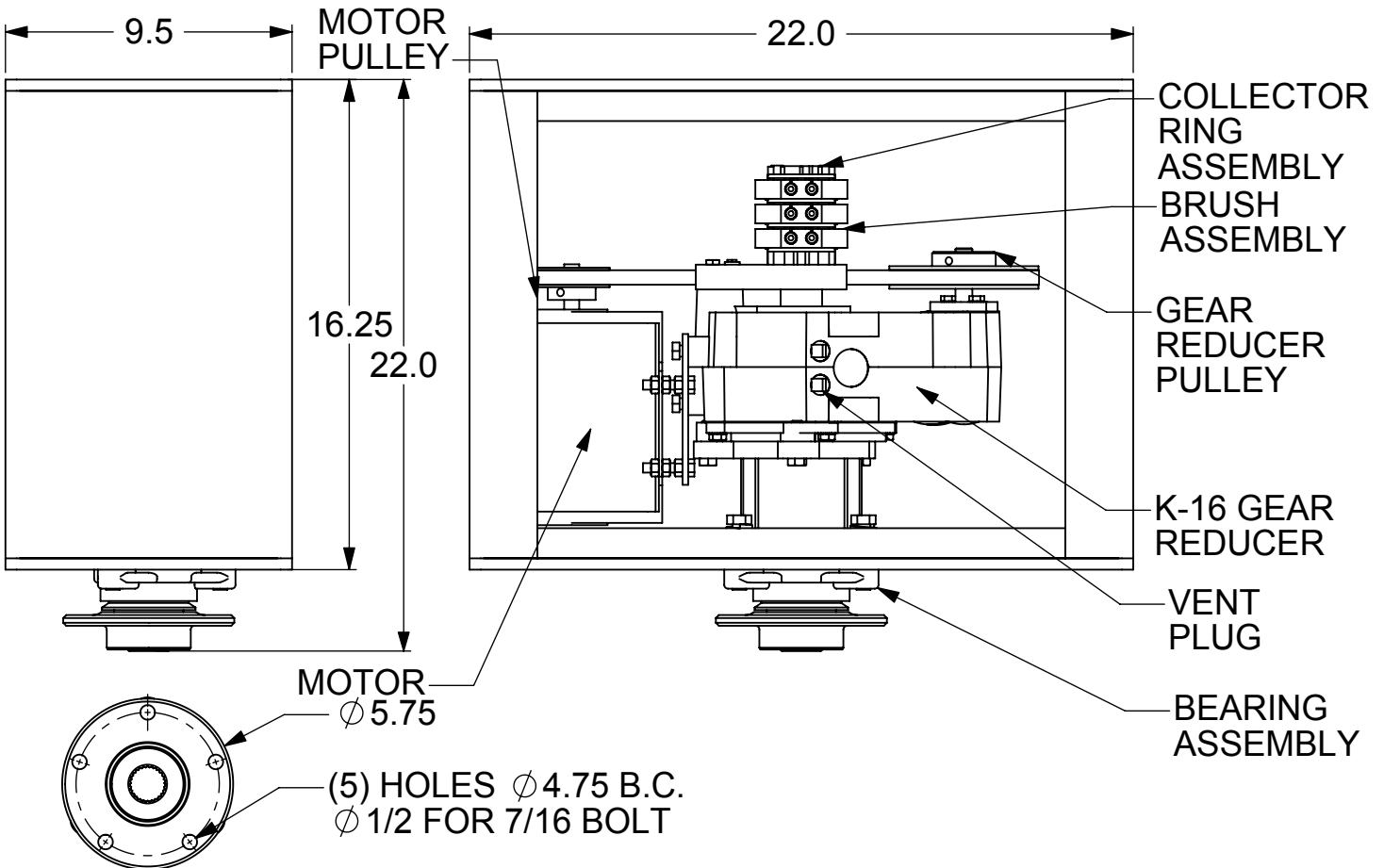

## DYNAPAC ROTATING COMPANY, INC.

338 Hansen Ave. • Salt Lake City, Utah 84115-5115  
 Phone 800-657-2650 • 801-485-2221 • Fax 801-485-2254  
 email: [info@dynapacrotating.com](mailto:info@dynapacrotating.com) • [www.dynapacrotating.com](http://www.dynapacrotating.com)

\*Higher amp loads available upon request