

Model K-25

(Part # 135001 321)

The K-25 can easily and reliably power larger displays. This rotator provides additional torque up to 130 ft-lbs to turn signs and exhibits requiring high torque.

| | |
|-------------------------------|-------------------------|
| WEIGHT CAPACITY..... | 500 lbs |
| MAX. ALLOWABLE SIZE..... | Contact Dynapac |
| HANGING WEIGHT CAPACITY..... | 500 lbs |
| RPM'S AVAILABLE..... | 1, 2 (std.), 3, 4, or 6 |
| TORQUE OUTPUT @ 2 RPM..... | 1600 In-lbs |
| MAX. SHEAR LOAD..... | 1080 lbs |
| MAX. BENDING LOAD..... | 1000 ft-lbs |
| COLLECTOR RING CAPACITY*..... | 15A @ 115V |
| MOTOR DRAW(@115 Volts)..... | 5.1A (587 watts) |
| SAFETY CLUTCH..... | Standard feature |
| MAIN DRIVE..... | Gear Reducer |
| SHIPPING WEIGHT..... | 97 lbs |

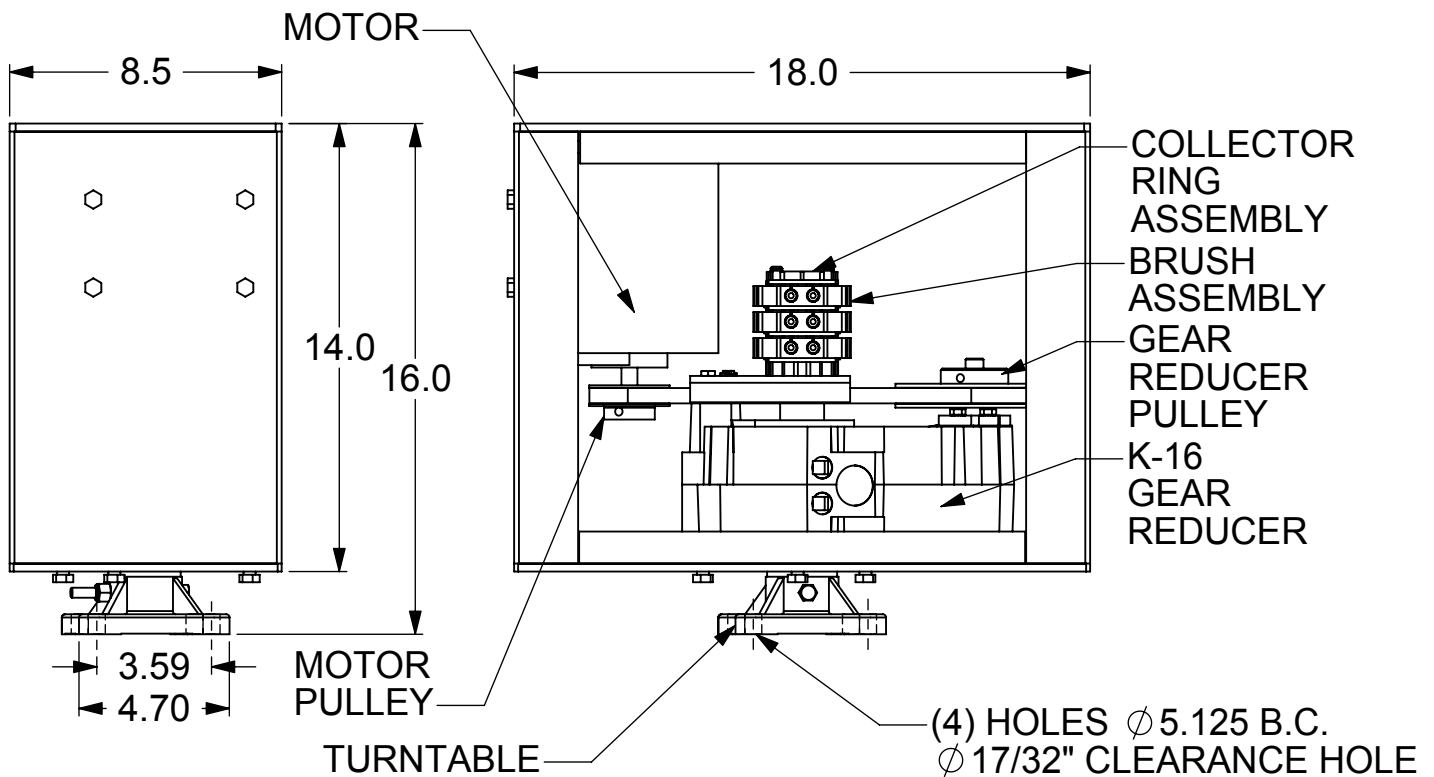

DYNAPAC ROTATING COMPANY, INC.

338 Hansen Ave. • Salt Lake City, Utah 84115-5115

Phone 800-657-2650 • 801-485-2221 • Fax 801-485-2254

email: info@dynapacrotating.com • www.dynapacrotating.com

*Higher amp loads available upon request